

T-Set[®] Setting Tool Product Catalog



 HUNTING



HUNTING

Firing Heads
Adapter Kits
Inspection Kits
Power Chargers and Igniters



T-Set® Setting Tool Catalog

| | |
|--|----------------|
| 01 Compact - Single Stage T-Set® | Page 01 |
| 1.50 in. (3.81 cm) O.D..... | .02 |
| 1.71 in. (4.34 cm) O.D..... | .05 |
| 2.50 in. (6.35 cm) O.D..... | .08 |
| 3.50 in. (8.89 cm) O.D. Self Bleeding..... | .11 |
| 3.63 in. (9.21 cm) O.D..... | .14 |
| 3.63 in. (9.21 cm) O.D. High Pressure..... | .16 |
| 3.63 in. (9.21 cm) O.D. High Pressure..... | .18 |
| | |
| 02 Multi-Stage T-Set® | Page 21 |
| 1.71 in. (4.34 cm) O.D..... | .22 |
| 2.13 in. (5.40 cm) O.D..... | .26 |
| 3.25 in. (8.25 cm) O.D..... | .30 |
| 4.50 in. (11.43 cm) O.D..... | .33 |

03 | Sizes 05 - 10 - 20 T-Set®

Page 37

| | |
|--|----|
| SIZE 05 | 38 |
| SIZE 10 | 42 |
| SIZE 10 Non-ported High Pressure | 44 |
| SIZE 10 Non-ported | 46 |
| SIZE 20 | 48 |
| SIZE 20 Non-ported High Pressure | 50 |
| SIZE 20 Non-ported | 52 |

04 | Firing Heads

| | |
|---|----|
| 2005-000-000 (Size 05 - 1-3/16 in.-12 "GO" Box)..... | 56 |
| 2010-000-000 (Size 10 - 1-3/16 in.-12 "GO" Box)..... | 58 |
| 2010-000-020 (Size 10 - 3-1/8 in. O.D. "GO" Quick-Change Assembly)..... | 60 |
| 2010-000-040 (Size 10 - 2-3/4 in. O.D. "GO" Quick-Change Assembly)..... | 62 |
| 2010-000-070 (Size 10 - 3-1/8 in. O.D. SIE Quick-Change Assembly)..... | 64 |
| 2010-000-090 (Size 10 - 2010-000-090)..... | 66 |
| 2020-000-000 (Size 20 - 1-3/16 in.-12 "GO" Box)..... | 68 |
| 2020-000-020 (Size 20 - 3-1/8 in. O.D. GO Quick-Change Assembly) | 70 |
| 2020-000-070 (Size 20 - 3-1/8 in. O.D. SIE Quick-Change Assembly)..... | 72 |
| 6110-000-000 (Size 1.5 in., 1.72 in., 2.13 in., 2.5 in. - 1-3/16 in.-12 "GO" Box) | 74 |

05 | Adapter Kits

| | |
|------------------------------|----|
| 1.71 in. (4.34 cm) O.D..... | 76 |
| 2.13 in. (5.40 cm) O.D..... | 77 |
| 3.25 in. (8.25 cm) O.D..... | 78 |
| 4.50 in. (11.43 cm) O.D..... | 79 |

06 | Inspection Kits

| | |
|--------------------------|----|
| WST-KIT-INSP-10-20 | 81 |
| WST-KIT-INSP-UNIV | 82 |

07 | Power Charges and Igniters

| | |
|--|----|
| Power Charges and Igniters for T-Set® Tools..... | 83 |
|--|----|

Compact Single Stage T-SET®

FEATURES

- Short compact design
- Self-bleeding compensating system
- Options for bleeder valves
- Black oxide coated components

BENEFITS

- Ideal for horizontal pump down operations
- Compensation oil level adjustments are not necessary
- Bleeder valves provide a safer option to bleed off pressure inside the tool at surface
- Black oxide coating improves corrosion and chemical resistance

The compact, single stage T-Set is the shortest setting tool in in the T-Set family. Its low weight and short length make it ideal for stage frac jobs requiring pump down operations.

The top cylinder is filled with oil and self-bleeds with increased temperature. The trouble-free design makes it quick and easy to redress at the wellsite providing fast turnaround times.

The ignition of a slow set power charge creates gas pressure inside the setting tool. The gas migrates through the piston initiating the setting sequence. The hydraulic oil slowly bleeds out of the tool providing a cushioning effect while setting. Once the required setting force is achieved, a shear stud breaks releasing the T-Set from the plug/packer.

1.50 in. (3.81 cm) O.D.
1-1/2 in. Shorty Setting Tool

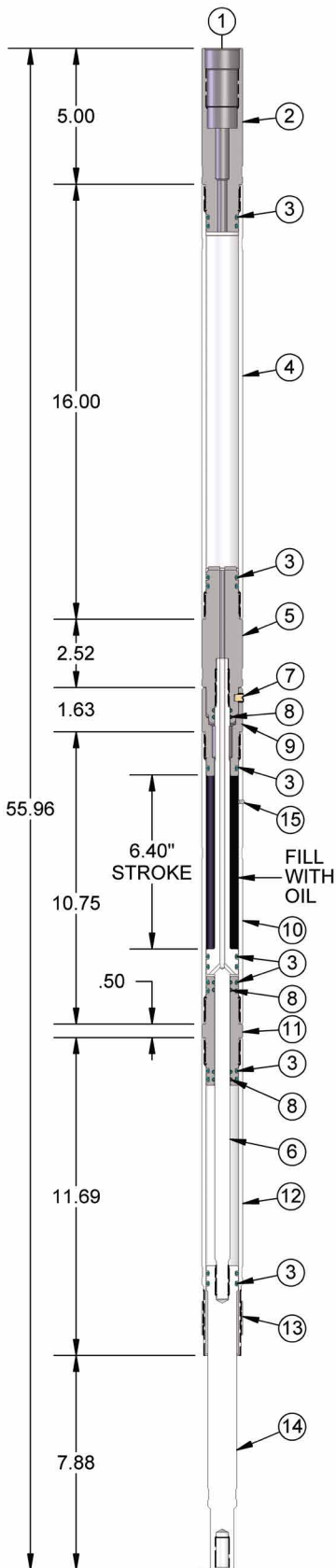

PARTS LIST

| ITEM | PART NUMBER | REQ. | DESCRIPTION |
|---|--------------|------|--|
| 1 | WST-1500-001 | | Assy. - 1.50 in. (3.81 cm) O.D. T-Set® - Top Connection to fit "GO" 1-7/16 in. O.D. High Pressure Firing Head - Incl. Items 2-15 |
| 2 | WST-1500-020 | 1 | Top Sub |
| 3* | 0111-213-090 | 13 | O-ring - 90 Duro. |
| 4 | WST-1500-021 | 1 | Power Charge Chamber |
| 5 | WST-1500-028 | 1 | Shear Sub - Non Ported |
| 6 | WST-1500-026 | 1 | Top Piston |
| 7* | 052-5304-003 | 1 | Brass Shear Screw - Approx. 2,300 lb. Shear |
| 8* | 0111-113-090 | 6 | O-ring - 90 Duro. |
| 9 | WST-1500-023 | 1 | Orifice Sub |
| 10 | WST-1500-024 | 1 | Top Cylinder |
| 11 | WST-1500-027 | 1 | Tandem Sub |
| 12 | WST-1500-025 | 1 | Bottom Cylinder |
| 13 | WST-1500-030 | 1 | Lock Ring |
| 14 | WST-1500-029 | 1 | Bottom Piston |
| 15* | WST-1718-019 | 1 | Nylon Plug |
| * | WST-1500-010 | | Redress Kit - for WST-1500-001 Incl. Items 3,7,8,15 |
| OPTIONAL EQUIPMENT NOT INCLUDED IN ASSY. WST-1500-001 | | | |
| 16 | WST-1500-022 | 1 | Shear Sub - Ported for Bleeder Valve |
| 17 | WST-BK05-137 | 1 | Retainer Nut |
| 18 | WST-BK05-136 | 1 | Rupture Disc |
| 19 | 0111-111-090 | 1 | O-ring - 90 Duro. |
| 20 | WST-2125-340 | | Rupture Wrench |
| | WST-BK05-138 | | Rupture Disc Kit - Incl. Items 18 & 19 |

| MAX STROKE | MAX PULL STRENGTH | UNPORTED MAX HYDROSTATIC PRESSURE | PORTED MAX HYDROSTATIC PRESSURE |
|---------------------|-------------------|-----------------------------------|---------------------------------|
| 6.40 in. (16.26 cm) | 10,000 lb. | 20,000 psi (1.379 bar) | 15,000 psi (1,034 bar) |

Power Charges and Igniters referenced at the back of this catalog

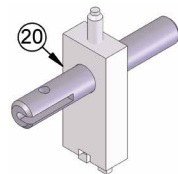

Rupture Wrench
WST-2125-340

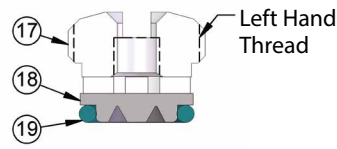

Rupture Disc Assy.
Items 17-19

1.50 in. (3.81 cm) O.D. Assembly Instructions

1. Install O-rings (3 & 8) then lubricate O-rings. Screw tandem sub (11) into top cylinder (10) using either end of the tandem sub. Make wrench tight. Wrench only on wrenching areas provided.



2. Install O-rings (3) then lubricate O-rings. Slide top piston (6) into top cylinder and through tandem sub bore until top piston bottoms in cylinder. Note: center hole faces up.

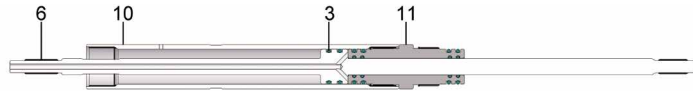

3. Install O-rings (3) then lubricate O-rings, threads, and bores. Slide bottom piston (14) inside lower end of bottom cylinder (12). Push piston upward in cylinder approximately 5 in. Install lock ring (13) onto bottom cylinder.

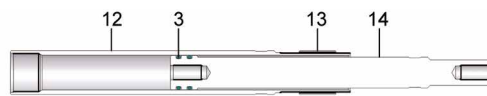

4. Join bottom piston (14) to top piston (6). Push bottom cylinder (12) upward and join it to tandem sub (11). Make wrench tight. Caution: nylon plug (15) positioned at top end of tool.

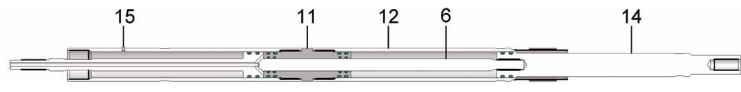

5. Remove tool from vise. Bump tool (view a) completely closed (on wooden block). Next, turn tool upright then fill top cylinder with motor oil level reaches groove at lower end of thread. Install O-rings (3) then lubricate. Install orifice sub (9). Excess oil will purge as sub is screwed in.

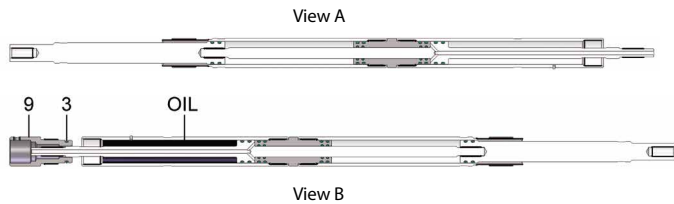

6. Return tool to vise. Make orifice sub (9) wrench tight to top cylinder. Install O-rings (3 & 8) then lubricate. Screw shear sub (5) to top piston. Hold back-up wrench on bottom piston (14) and tighten shear sub which will ensure all inside connections are tight. Rotate shear sub clockwise until shear screw holes align then install shear screw (7).



7. Install rupture disc assembly (17, 18, 19) if used. Screw power charge chamber (4) to shear sub (16). Install power charge. Make sure open end of power charge is facing up.



8. Install O-rings (3) then lubricate. Screw top sub (2) to power charge chamber wrench tight. Check igniter by first removing ground wire from contact spring then checking resistivity (51 ohms) with blasting galvanometer. Next, wrap ground wire around case of igniter body then place igniter in firing head. Tool is now assembled. Attach appropriate firing adapter, collar locator, and setting adapters.



1.50 in. (3.81 cm) O.D.
Minimum and Maximum Wear Diameters

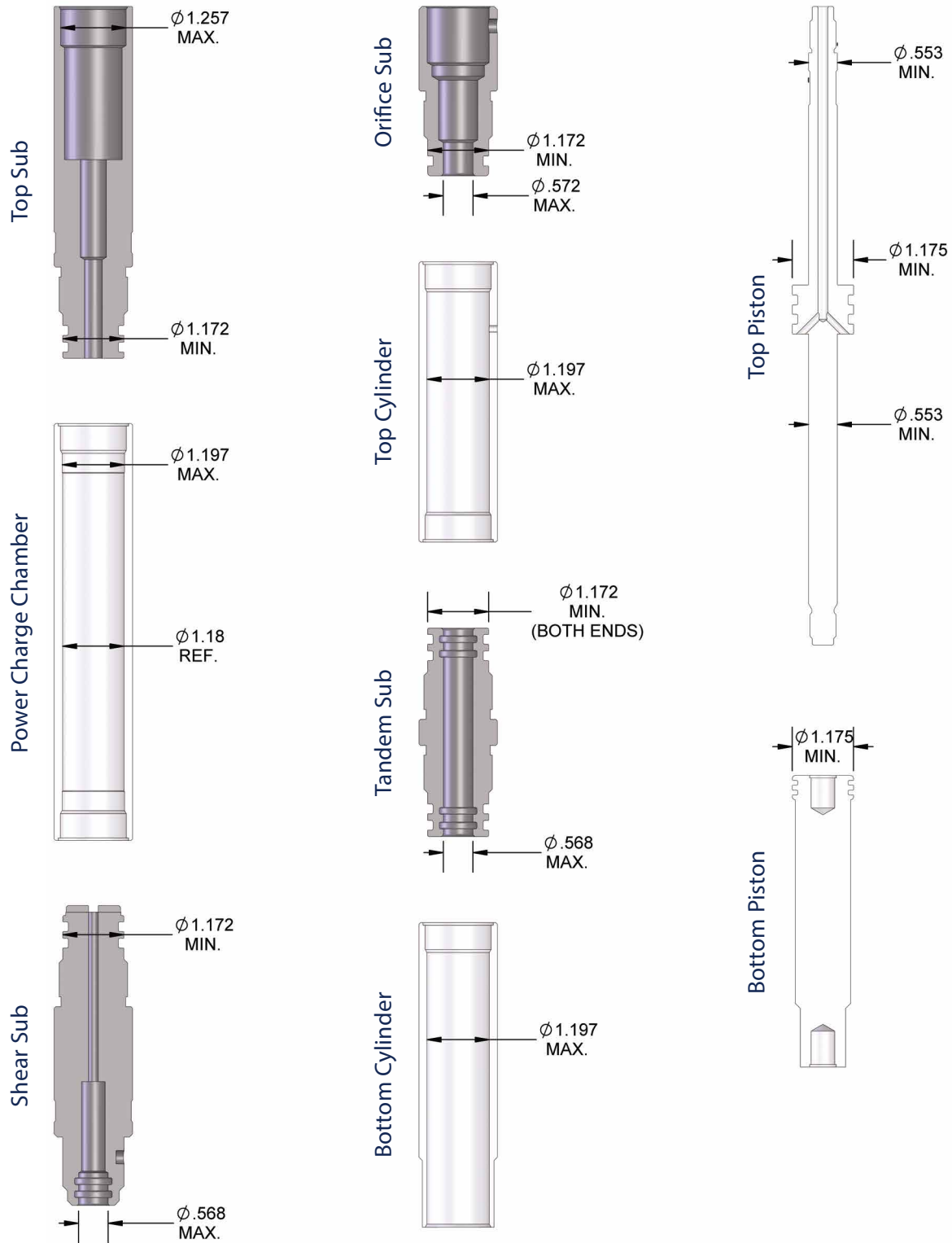

The illustrations shown above list suggested critical minimum and maximum wear diameters.

1.71 in. (4.34 cm) O.D.
1-11/16 in. Shorty Setting Tool

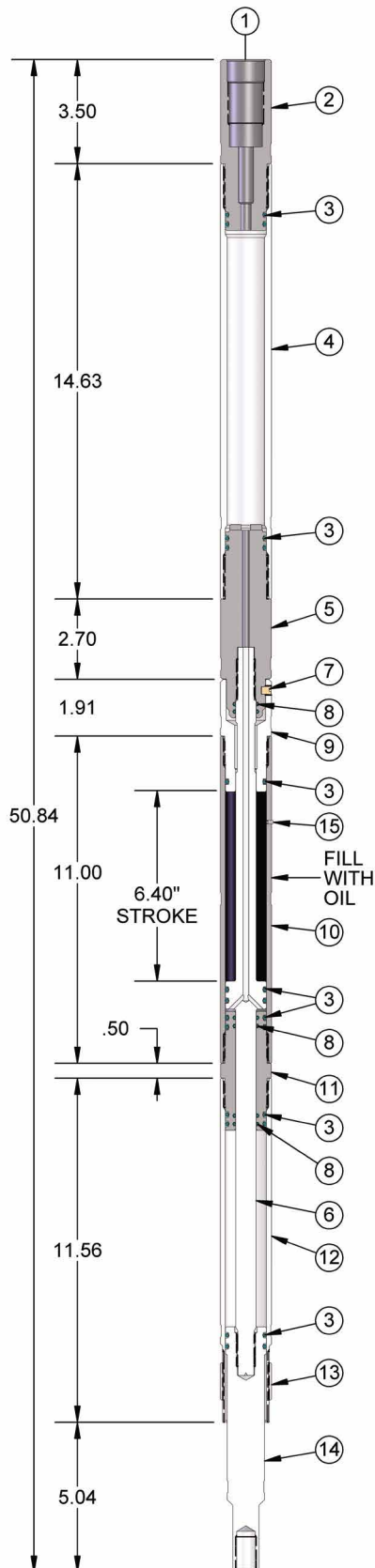

PARTS LIST

| ITEM | PART NUMBER | REQ. | DESCRIPTION |
|---|--------------|------|--|
| 1 | WST-1718-001 | | Assy. - 1.71 in. (4.34 cm) O.D. T-Set® - Top Connection to fit "GO" 1-7/16 in. O.D. High Pressure Firing Head - Incl. Items 2-15 |
| 2 | WST-1718-020 | 1 | Top Sub |
| 3* | 0111-216-090 | 13 | O-ring - 90 Duro. |
| 4 | WST-1718-021 | 1 | Power Charge Chamber |
| 5 | WST-1718-028 | 1 | Shear Sub - Non Ported |
| 6 | WST-1718-026 | 1 | Top Piston |
| 7* | 052-5304-003 | 1 | Brass Shear Screw - Approx. 2,300 lb. Shear |
| 8* | 0111-115-090 | 6 | O-ring - 90 Duro. |
| 9 | WST-1718-023 | 1 | Orifice Sub |
| 10 | WST-1718-024 | 1 | Top Cylinder |
| 11 | WST-1718-027 | 1 | Tandem Sub |
| 12 | WST-1718-025 | 1 | Bottom Cylinder |
| 13 | WST-1718-030 | 1 | Lock Ring |
| 14 | WST-1718-029 | 1 | Bottom Piston |
| 15* | WST-1718-019 | 1 | Nylon Plug |
| * | WST-1718-010 | | Redress Kit - for WST-1718-001 - Incl. Items 3,7,8,15 |
| OPTIONAL EQUIPMENT NOT INCLUDED IN ASSY. WST-1718-001 | | | |
| 16 | WST-1718-022 | 1 | Shear Sub - Ported for Bleeder Valve |
| 17 | WST-BK05-137 | 1 | Retainer Nut |
| 18 | WST-BK05-136 | 1 | Rupture Disc |
| 19 | 0111-111-090 | 1 | O-ring - 90 Duro. |
| 20 | WST-2125-340 | | Rupture Wrench |
| | WST-BK05-138 | | Rupture Disc Kit - Incl. Items 18 & 19 |

| MAX STROKE | MAX PULL STRENGTH | UNPORTED MAX HYDROSTATIC PRESSURE | PORTED MAX HYDROSTATIC PRESSURE |
|---------------------|-------------------|-----------------------------------|---------------------------------|
| 6.40 in. (16.26 cm) | 13,000 lb. | 20,000 psi (1.379 bar) | 15,000 psi (1,034 bar) |

Power Charges and Igniters referenced at the back of this catalog

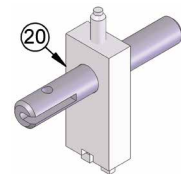

Rupture Wrench
WST-2125-340

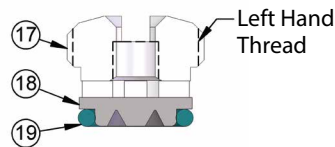

Rupture Disc Assy.
Items 17-19

1.71 in. (4.34 cm) O.D. Assembly Instructions

1. Install O-rings (3 & 8) then lubricate O-rings. Screw tandem sub (11) into top cylinder (10) using either end of the tandem sub. Make wrench tight. Wrench only on wrenching areas provided.



2. Install O-rings (3) then lubricate O-rings. Slide top piston (6) into top cylinder and through tandem sub bore until top piston bottoms in cylinder. Note: center hole faces up.

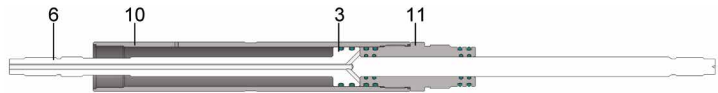

3. Install O-rings (3) then lubricate O-rings, threads, and bores. Slide bottom piston (14) inside lower end of bottom cylinder (12). Push piston upward in cylinder approximately 5 in. Install lock ring (13) onto bottom cylinder.

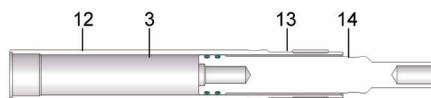

4. Join bottom piston (14) to top piston (6). Push bottom cylinder (12) upward and join it to tandem sub (11). Make wrench tight. Caution: nylon plug (15) positioned at top end of tool.

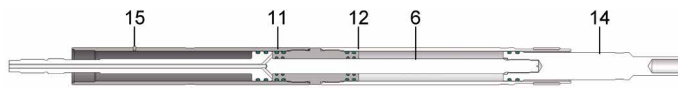

5. Remove tool from vise. Bump tool (view a) completely closed (on wooden block). Next, turn tool upright then fill top cylinder with motor oil level reaches groove at lower end of thread. Install O-rings (3) then lubricate. Install orifice sub (9). Excess oil will purge as sub is screwed in.

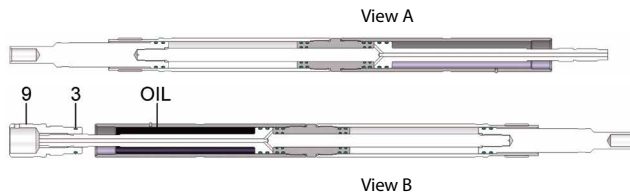

6. Return tool to vise. Make orifice sub (9) wrench tight to top cylinder. Install O-rings (3 & 8) then lubricate. Screw shear sub (5) to top piston. Hold back-up wrench on bottom piston (14) and tighten shear sub which will ensure all inside connections are tight. Rotate shear sub clockwise until shear screw holes align then install shear screw (7).

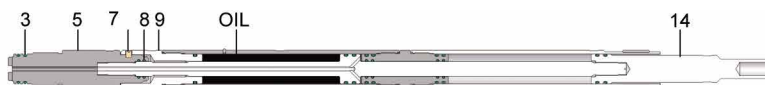

7. Install rupture disc assembly (17, 18, 19) if used. Screw power charge chamber (4) to shear sub (16). Install power charge. Make sure open end of power charge is facing up.



8. Install O-rings (3) then lubricate. Screw top sub (2) to power charge chamber wrench tight. Check igniter by first removing ground wire from contact spring then checking resistivity (51 ohms) with blasting galvanometer. Next, wrap ground wire around case of igniter body then place igniter in firing head. Tool is now assembled. Attach appropriate firing adapter, collar locator, and setting adapters.



1.71 in. (4.34 cm) O.D.
Minimum and Maximum Wear Diameters

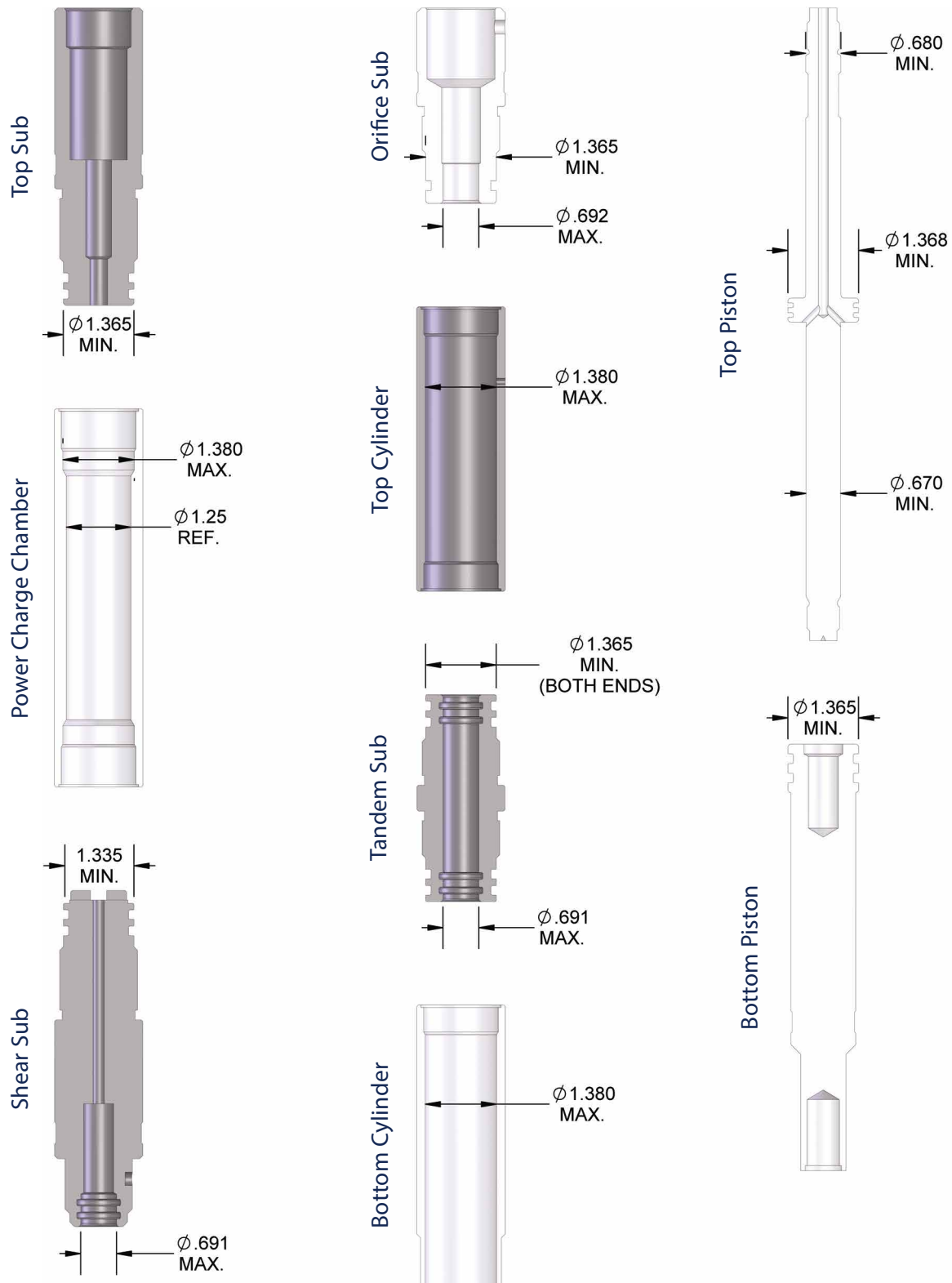

The illustrations shown above list suggested critical minimum and maximum wear diameters.

2.50 in. (6.35 cm) O.D.
2-1/2 in. Shorty Setting Tool

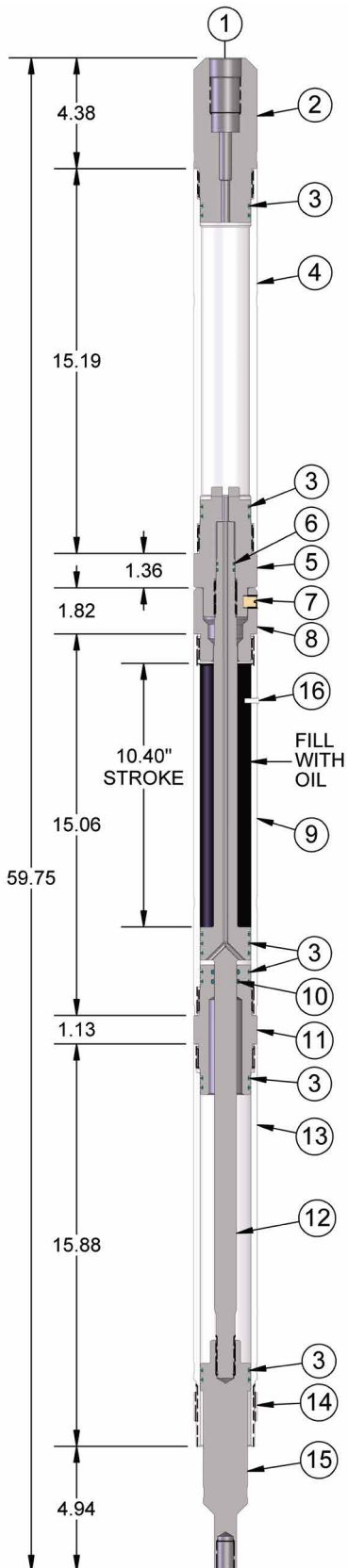

PARTS LIST

| ITEM | PART NUMBER | REQ. | DESCRIPTION |
|------|--------------|------|--|
| 1 | WST-2500-001 | | Assy. - 2.50 in. (6.35 cm) O.D. T-Set* Self Bleeding - Top Connection to fit "GO" 1-7/16 in. O.D. High Pressure Firing Head - Incl. Items 2-16 |
| 2 | WST-2500-020 | 1 | Top Sub |
| 3* | 0111-224-090 | 13 | O-ring - 90 Duro. |
| 4 | WST-2500-021 | 1 | Power Charge Chamber |
| 5 | WST-2500-028 | 1 | Shear Sub |
| 6* | 0111-113-090 | 2 | O-ring - 90 Duro. |
| 7* | 052-5303-003 | 1 | Brass Shear Screw - Approx. 6,500 lb. Shear |
| 8 | WST-2500-023 | 1 | Orifice Sub |
| 9 | WST-2500-024 | 1 | Top Cylinder - Ported for Self Bleeding |
| 10* | 0111-212-090 | 2 | O-ring - 90 Duro. |
| 11 | WST-2500-027 | 1 | Connector Sub |
| 12 | WST-2500-026 | 1 | Top Piston |
| 13 | WST-2500-025 | 1 | Bottom Cylinder |
| 14 | WST-2500-030 | 1 | Lock Ring |
| 15 | WST-2500-029 | 1 | Bottom Piston |
| 16* | WST-5321-019 | 1 | Nylon Plug |
| * | WST-2500-010 | | Redress Kit - for WST-2500-001 - Incl. Items 3,6,7,10,16 |

| MAX STROKE | MAX PULL STRENGTH | MAX HYDROSTATIC PRESSURE |
|----------------------|-------------------|--------------------------|
| 10.40 in. (26.42 cm) | 30,000 lb. | 20,000 psi (1.379 bar) |

Power Charges and Igniters referenced at the back of this catalog

2.50 in. (6.35 cm) O.D. Assembly Instructions

1. Install O-rings (3) on bottom piston (15) insert bottom piston approximately halfway inside bottom cylinder (13). Install lock ring (14).

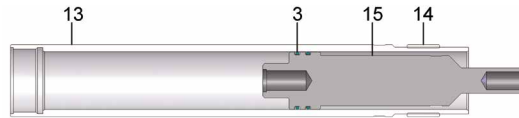

2. Install O-rings (3 & 6) on top piston (12). Install O-rings (3 & 10) on connector sub (11). Slide connector sub on top piston. Caution: Internal O-rings positioned toward top of piston.

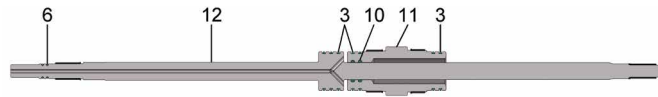

3. Install bottom cylinder and bottom piston (13 & 15) over lower end of top piston (12).

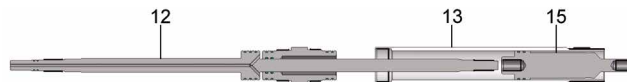

4. Slide bottom cylinder up and thread to connector sub. Finish threading and tighten bottom piston to top piston.

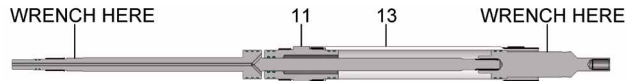

5. Install nylon plug (16) in top cylinder (9). Thread top cylinder (9) to connector sub (11). Caution: nylon plug positioned at top end of tool.

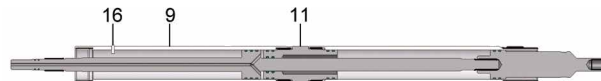

6. Bump top piston fully closed. Turn tool upright and fill top cylinder with motor oil until level reaches bottom thread. Attach orifice sub (8).



7. Install O-rings (3) on shear sub (5). Screw shear sub to top piston. Tighten the shear sub, top piston and bottom piston connections by turning the shear sub while holding the bottom piston.



8. Attach power charge chamber (4) to shear sub (5). Tighten the power charge chamber, shear sub, top piston, and bottom piston connections by turning the power charge chamber while holding the bottom piston. Align the holes in orifice sub and shear sub then install brass shear screw (7).



9. Insert power charge (open end up) into power charge chamber (4). Install O-rings (3) on top sub (2). Screw top sub to power charge chamber.



2.50 in. (6.35 cm) O.D.
Minimum and Maximum Wear Diameters

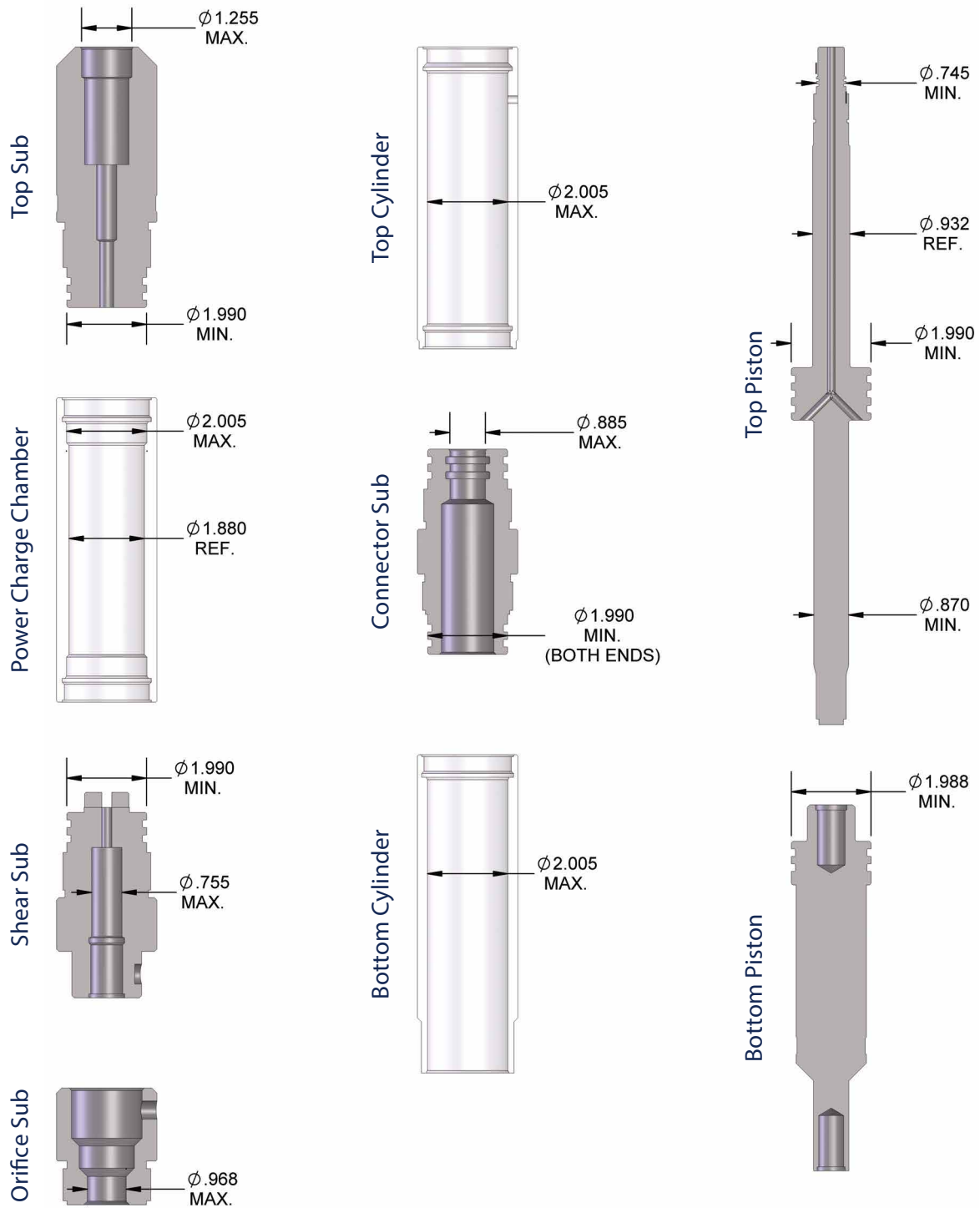

The illustrations shown above list suggested critical minimum and maximum wear diameters.

3.50 in. (8.89 cm) O.D. Self Bleeding

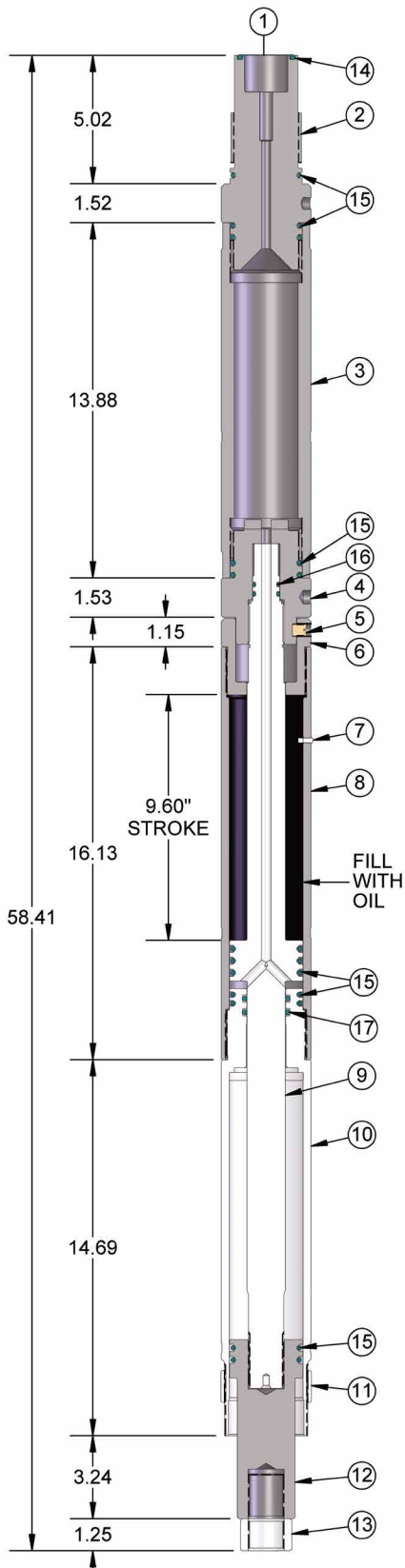

PARTS LIST

| ITEM | PART NUMBER | REQ. | DESCRIPTION |
|------|--------------|------|---|
| 1 | WST-5321-501 | | Assy. - 3.50 in. (8.89 cm) O.D. T-Set [®] Top Connection to fit 3.25 in. (8.25 cm) Quick Change Assy. - Incl. items 2-17 |
| 2 | WST-5321-023 | 1 | Top Sub - to fit 3.25 in. (8.25 cm) Quick Change Assy. |
| 3 | WST-5321-020 | 1 | Power Charge Chamber |
| 4 | WST-5321-022 | 1 | Shear Sub |
| 5* | 052-5303-003 | 1 | Brass Shear Screw - Approx. 6, 500 lb. Shear |
| 6 | WST-5321-509 | 1 | Orifice Sub |
| 7* | WST-5321-019 | 1 | Nylon Plug |
| 8 | WST-5321-512 | 1 | Top Cylinder |
| 9 | WST-5321-021 | 1 | Top Piston |
| 10 | 066-0350-129 | 1 | Bottom Cylinder - High Pressure |
| 11 | WST-3625-130 | 1 | Lock Ring |
| 12 | 066-0350-136 | 1 | Bottom Piston - High Pressure |
| 13 | WST-3625-131 | 1 | Lock Nut |
| 14* | 0111-328-090 | 1 | O-ring - 90 Duro. |
| 15* | 0111-332-090 | 12 | O-ring - 90 Duro. |
| 16* | 0111-211-090 | 2 | O-ring - 90 Duro. |
| 17* | 0111-325-090 | 2 | O-ring - 90 Duro. |
| * | WST-5321-110 | | Redress Kit - for WST-5321-101 Incl. Items 5,7,14,15,16,17 |

| MAX STROKE | MAX PULL STRENGTH | MAX HYDROSTATIC PRESSURE |
|---------------------|-------------------|--------------------------|
| 9.60 in. (24.38 cm) | 55,000 lb. | 15,000 psi (1,034 bar) |

Power Charges and Igniters referenced at the back of this catalog

3.50 in. (8.89 cm) O.D. Assembly Instructions

1. Install O-rings (15 & 17) on bottom cylinder (10). Install O-rings (15 & 16) on top piston (9). Slide lower end of top piston (9) inside upper end of top cylinder all the way. Screw lock ring (11) on bottom cylinder.

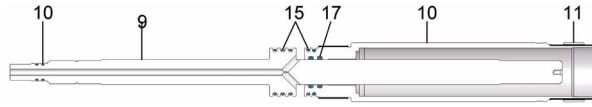

2. Slide top cylinder (8) over top piston and screw to bottom cylinder. Caution: the self bleeder port must be positioned the upper end of the tool. Insert plastic plug (7) in bleed hole of top cylinder.

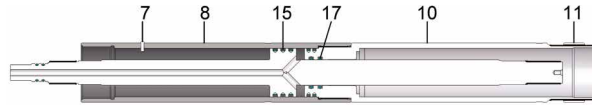

3. Install O-rings (15) on bottom piston (12). Screw bottom piston to top piston.

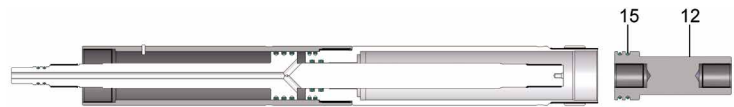

4. Bump top piston fully closed. Turn tool upright and fill top cylinder with motor oil until level reaches bottom thread. Attach orifice sub (6).

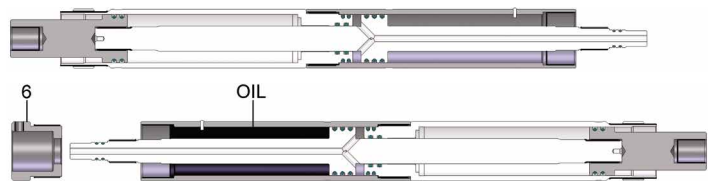

5. Install O-rings (15) on shear sub (4). Screw shear sub to top piston.

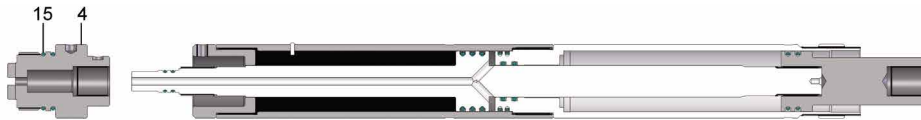

6. Align holes and install brass shear screw (5). Attach power charge chamber (3).



7. Insert power charge (open end up) into power charge chamber. Install O-rings (14 & 15) to top sub (2). Screw top sub (2). Screw top sub to power charge chamber.



3.50 in. (8.89 cm) O.D.
Minimum and Maximum Wear Diameters

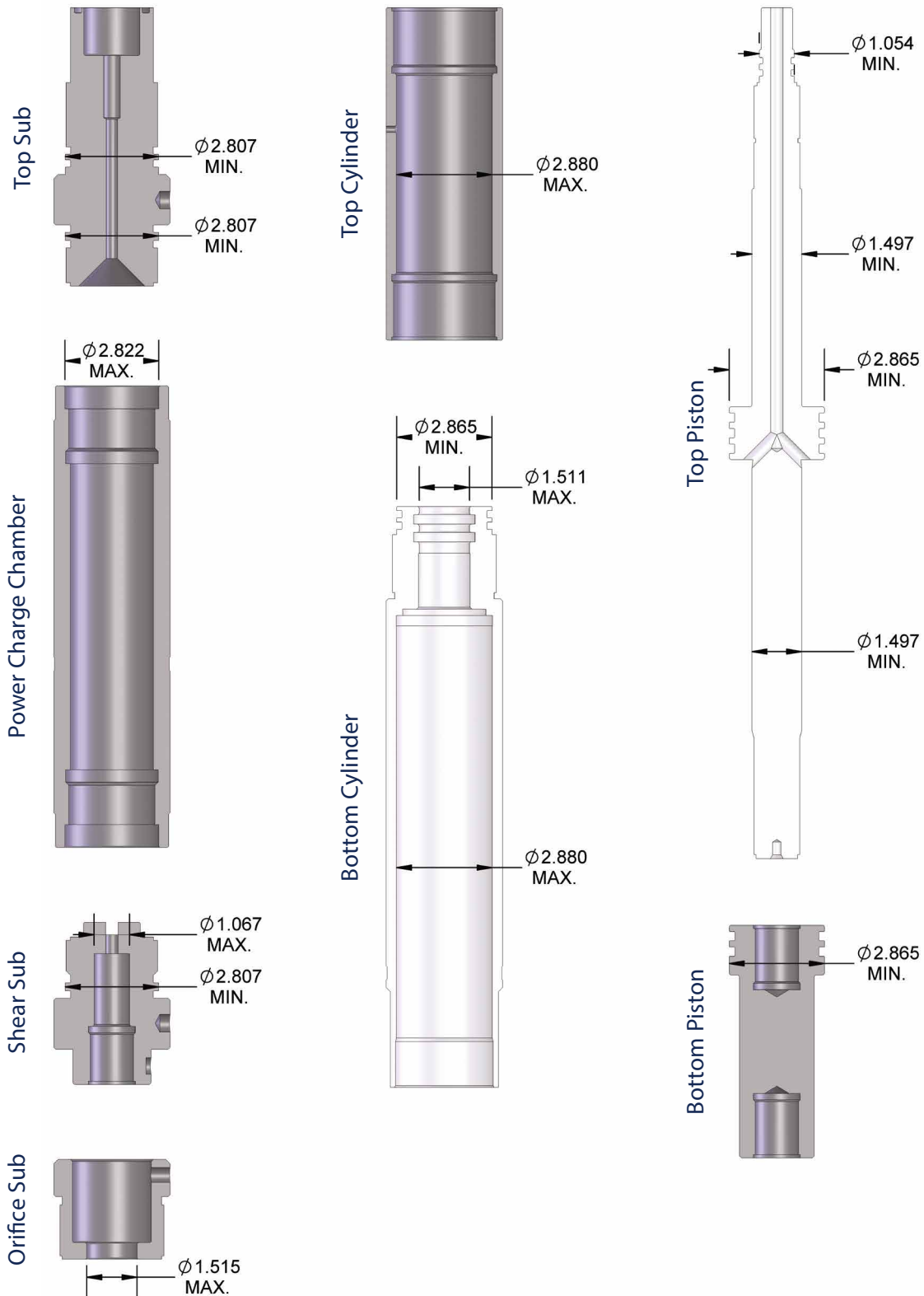

The illustrations shown above list suggested critical minimum and maximum wear diameters.

3.63 in. (9.21 cm) O.D.
3-5/8 in. Compact Setting Tool

Obsolete
March 31, 2015
Replacement: WST-3625-501

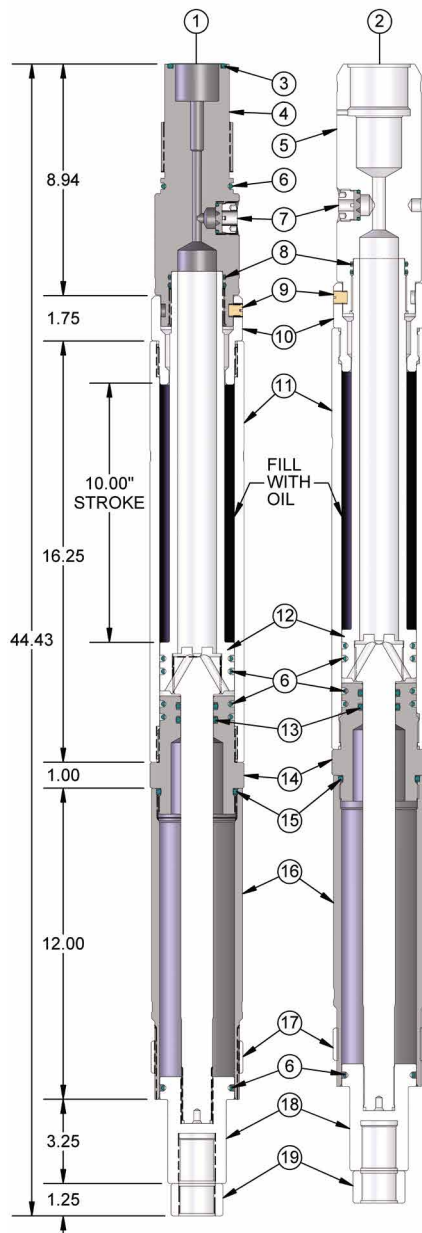

PARTS LIST

| ITEM | PART NUMBER | REQ. | DESCRIPTION |
|------|---------------|------|---|
| 1 | WST-3625-101 | | Assy. - 3.63 in. (9.21 cm) O.D. - Top Connection to fit 3.25 in. (8.25 cm) Quick Change Assy. - Incl. Items 3,4, & 6-22 |
| 2 | WST-3625-102 | | Assy. - 3.63 in. (9.21 cm) O.D. Setting Tool - Top Connection to fit Baker Size #10 Firing Head - Incl. Items 5 & 7-22 |
| 3* | 0111-328-090 | 1 | O-ring - 90 Duro. |
| 4 | WST-3625-120 | 1 | Top Sub - to fit 3.25 in. (8.25 cm) Quick Change Assy. |
| 5 | WST-3625-132 | 1 | Top Sub - to fit Baker Size #10 Firing Head |
| 6* | 0111-332-090 | 6 | O-ring - 90 Duro. |
| 7 | WST-3625-135 | 1 | Assy. - Disc Type Bleeder Valve - Incl. Items 20, 21, 22 |
| 8* | 0111-226-090 | 2 | O-ring - 90 Duro. |
| 9* | 052-5303-003 | 1 | Brass Shear Screw - Approx. 6,500 lb. Shear |
| 10 | WST-3625-121 | 1 | Orifice Sub |
| 11 | WST-3625-125 | 1 | Top Cylinder |
| 12 | WST-3625-122 | 1 | Top Piston |
| 13* | 0111-322-090 | 2 | O-ring - 90 Duro. |
| 14 | WST-3625-126 | 1 | Connector Sub |
| 15* | 0111-335-090 | 1 | O-ring - 90 Duro. |
| 16 | WST-3625-127 | 1 | Bottom Cylinder |
| 17 | WST-3625-130 | 1 | Lock Ring |
| 18 | WST-3625-128 | 1 | Bottom Piston |
| 19 | WST-3625-131 | 1 | Lock Nut |
| 20 | WST-3625-137 | 1 | Retainer Nut - for Disc Type Bleeder Valve |
| 21 | WST-3625-136 | 1 | Puncture Disc - for Disc Type Bleeder Valve |
| 22* | 0111-213-090 | 1 | O-ring - 90 Duro. - for Disc Type Bleeder Valve |
| 23 | WST-3625-140 | | Rupture Wrench |
| * | WST-3625-110 | | Redress Kit - for WST-3625-101 Incl. Items 3,6,8,9,13,15,22 |
| * | WST-3625-110D | | Redress Kit - for WST-3625-101 W/Disc Incl. Items 3,6,8,9,13,15,21,22 |
| * | WST-3625-112 | | Redress Kit - for WST-3625-102 Incl. Items 6,8,9,13,15,22 |
| | WST-3625-138 | | Rupture Disc Kit Bleed Valve - Incl. Items 21 & 22 |

| MAX STROKE | MAX PULL STRENGTH | MAX HYDROSTATIC PRESSURE |
|-------------------------|-------------------|--------------------------|
| 10.00 in. (25.40 cm) | 55,000 lb. | 10,000 psi (689 bar) |

Power Charges and Igniters referenced at the back of this catalog

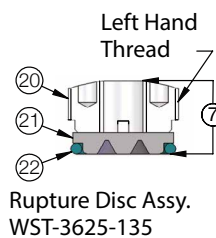
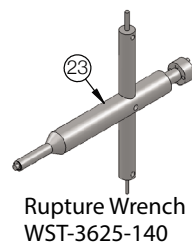

3.63 in. (9.21 cm) O.D. Assembly Instructions

1. Install O-rings (6, 13 & 15). Screw connector sub (14) to either end of top cylinder (11).

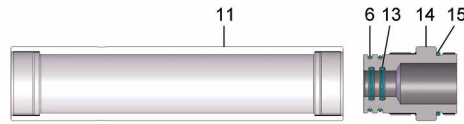

2. Install O-rings (6). Place top piston (12), lower end first, inside top cylinder and connector sub.

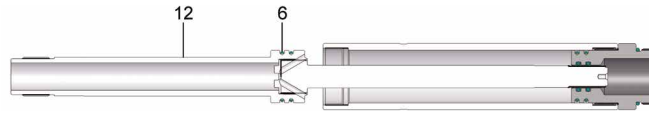

3. Bump top piston fully closed inside top cylinder and connector sub. Bump on wooden block only.

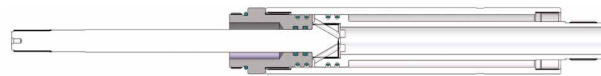

4. Turn tool upright and fill reservoir with motor oil to bottom of threads.

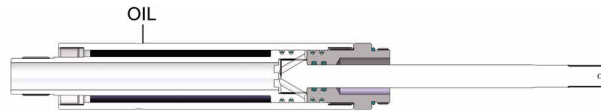

5. Screw orifice sub (10) to top cylinder.

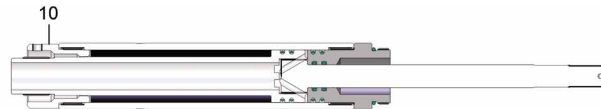

6. Install O-rings (3, 6 & 8). Install bleeder valve (7) in top sub (4). Place power charge (open end up) inside top piston. Screw top sub (4) to top piston (12). Do not allow oil to leak out of reservoir.

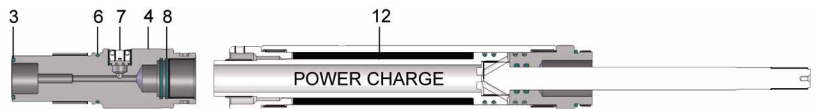

7. Screw bottom cylinder (16) to connector sub (14). Screw lock ring (17) on bottom cylinder.



8. Install O-rings (6). Screw bottom piston (18) to top piston. Wrench tighten the top sub, top piston, and bottom piston by holding backup wrench on top sub and tightening bottom piston. Next, rotate top sub until the shear screw (9) can be installed into tapped hole of orifice sub and blind hole provided in top sub. Finally, install igniter assembly and 3-1/4 in. O.D. quick change assembly.

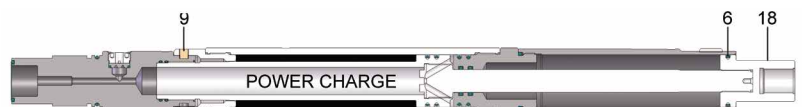

3.63 in. (9.21 cm) O.D. High Pressure, 15,000 PSI Hydrostatic 3-5/8 in. Compact Setting Tool

Obsolete
March 31, 2015
Replacement: WST-3625-501

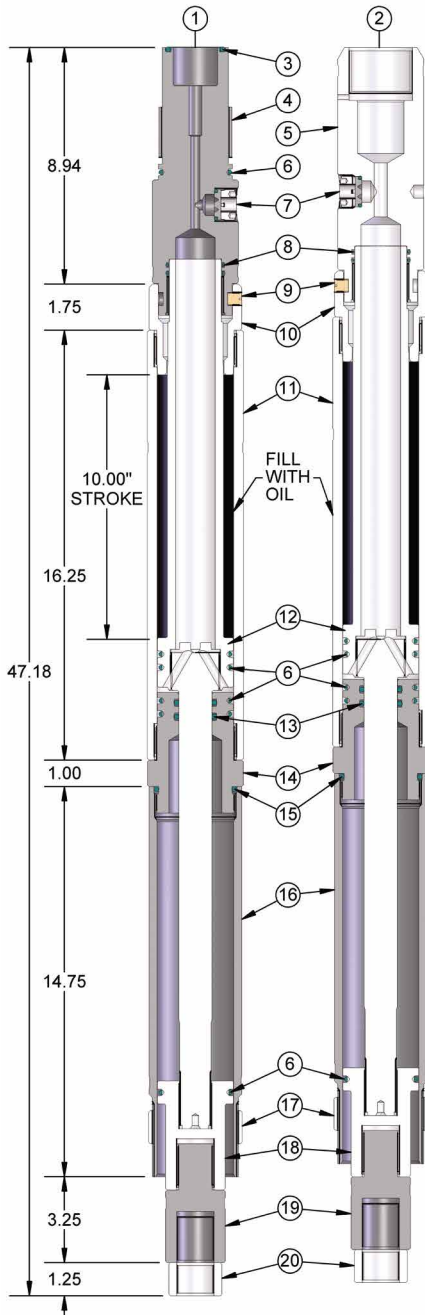

PARTS LIST

| ITEM | PART NUMBER | REQ. | DESCRIPTION |
|------|---------------|------|---|
| 1 | WST-3625-105 | | Assy. - 3.63 in. (9.21 cm) O.D. T-Set [®] - High Pressure - Top Connection to fit 3.25 in. (8.25 cm) Quick Change Assy.- Incl. Items 3,4, & 6-23 |
| 2 | WST-3625-106 | | Assy. - 3.63 in. (9.21 cm) O.D. T-Set [®] - High Pressure - Top Connection to fit Baker Size #10 Firing Head - Incl. Items 5 & 7-23 |
| 3* | 0111-328-090 | 1 | O-ring - 90 Duro. |
| 4 | WST-3625-120 | 1 | Top Sub - to fit 3.25 in. (8.25 cm) Quick Change Assy. |
| 5 | WST-3625-132 | 1 | Top Sub - to fit Baker Size #10 Firing Head |
| 6* | 0111-332-090 | 6 | O-ring - 90 Duro. |
| 7 | WST-3625-135 | 1 | Assy. - Disc Type Bleeder Valve - Incl. Items 21,22,23 |
| 8* | 0111-226-090 | 2 | O-ring - 90 Duro. |
| 9* | 052-5303-003 | 1 | Brass Shear Screw - Approx. 6,500 lb. Shear |
| 10 | WST-3625-121 | 1 | Orifice Sub |
| 11 | WST-3625-125 | 1 | Top Cylinder |
| 12 | WST-3625-122 | 1 | Top Piston |
| 13* | 0111-322-090 | 2 | O-ring - 90 Duro. |
| 14 | WST-3625-126 | 1 | Connector Sub |
| 15* | 0111-335-090 | 1 | O-ring - 90 Duro. |
| 16 | WST-3625-147 | 1 | Bottom Cylinder - High Pressure Tool |
| 17 | WST-3625-130 | 1 | Lock Ring |
| 18 | WST-3625-128 | 1 | Bottom Piston |
| 19 | WST-3625-148 | 1 | Piston Extension - High Pressure Tool |
| 20 | WST-3625-131 | 1 | Lock Nut |
| 21 | WST-3625-137 | 1 | Retainer Nut - for Disc Type Bleeder Valve |
| 22 | WST-3625-136 | 1 | Puncture Disc - for Disc Type Bleeder Valve |
| 23* | 0111-213-090 | 1 | O-ring - 90 Duro. - for Bleeder Valve |
| 24 | WST-3625-140 | | Rupture Wrench |
| * | WST-3625-110 | | Redress Kit - for WST-3625-105 Incl. Items 3,6,8,9,13,15,23 |
| * | WST-3625-110D | | Redress Kit - for WST-3625-105 W/Disc Incl. Items 3,6,8,9,13,15,22,23 |
| * | WST-3625-112 | | Redress Kit - for WST-3625-106 Incl. Items 6,8,9,13,15,23 |
| | WST-3625-138 | | Rupture Disc Kit - Incl. Items 22 & 23 |

| MAX STROKE | MAX PULL STRENGTH | MAX HYDROSTATIC PRESSURE |
|-------------------------|-------------------|--------------------------|
| 10.00 in. (25.40 cm) | 55,000 lb. | 15,000 psi (1,034 bar) |

Power Charges and Igniters referenced at the back of this catalog

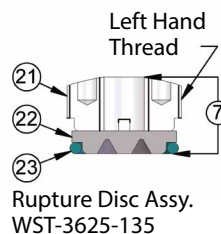
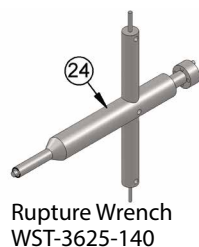

3.63 in. (9.21 cm) O.D. High Pressure Assembly Instructions

1. Install O-rings (6, 13 & 15). Screw connector sub (14) to either end of top cylinder (11).

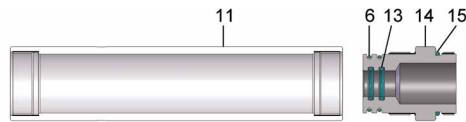

2. Install O-rings (6). Place top piston (12), lower end first, inside top cylinder and connector sub.

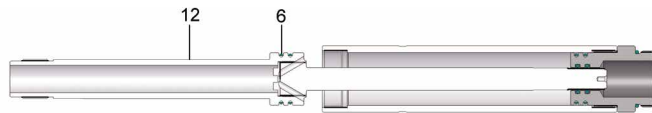

3. Bump top piston fully closed inside top cylinder and connector sub. Bump on wooden block only.

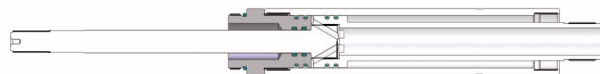

4. Turn tool upright and fill reservoir with motor oil to bottom of threads.

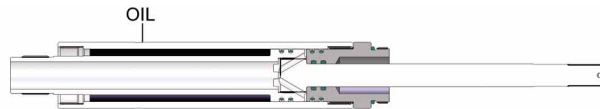

5. Screw orifice sub (10) to top cylinder.

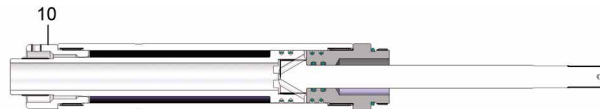

6. Install O-rings (3, 6 & 8). Install bleeder valve (7) in top sub (4). Place power charge (open end up) inside top piston. Screw top sub (4) to top piston (12). Do not allow oil to leak out of reservoir.

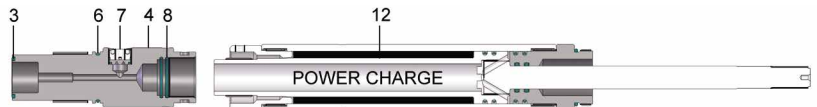

7. Screw bottom cylinder (16) to connector sub (14). Screw lock ring (17) on bottom cylinder.

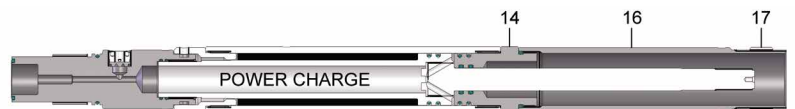

8. Install O-rings (6). Screw bottom piston (18) to top piston. Wrench tighten the top sub, top piston, and bottom piston by holding backup wrench on top sub and tightening bottom piston. Next, rotate top sub until the shear screw (9) can be installed into tapped hole of orifice sub and blind hole provided in top sub. Finally, install igniter assembly and 3-1/4 in. O.D. quick change assembly.

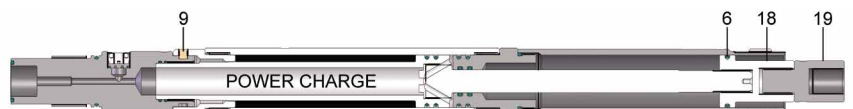

3.63 in. (9.21 cm) O.D. High Pressure 3-5/8 in. Compact Setting Tool

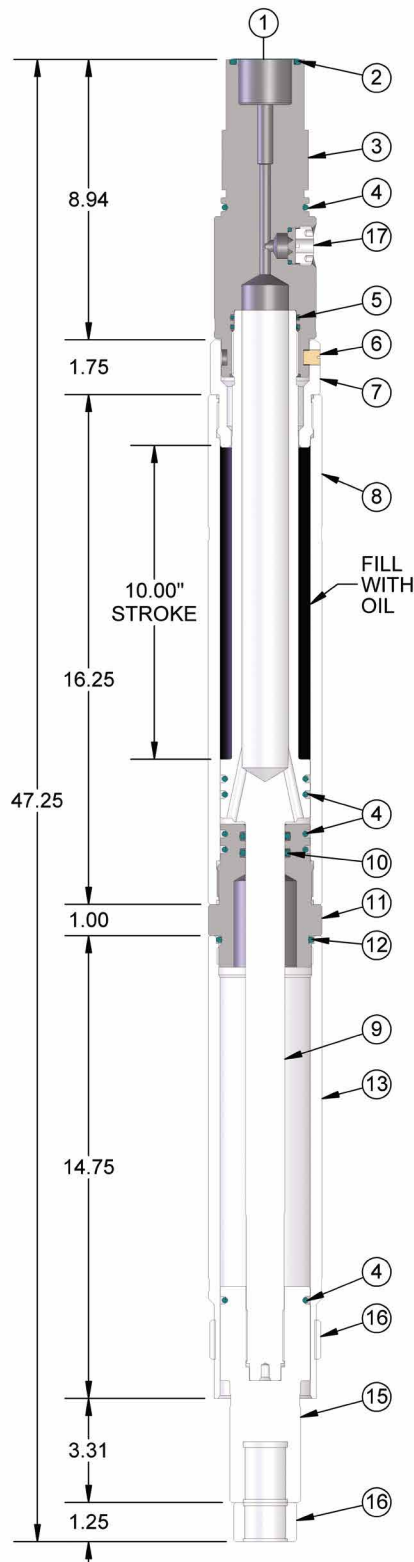

PARTS LIST

| ITEM | PART NUMBER | REQ. | DESCRIPTION |
|------|---------------|------|---|
| 1 | WST-3625-501 | | Assy. - 3.63 in. (9.21 cm) O.D. T-Set® - High Pressure Top connection to fit 3.25 in. (8.25 cm) Quick change assy. - incl. items 2-20 |
| 2* | 0111-328-090 | 1 | O-ring - 90 Duro. |
| 3 | WST-3625-120 | 1 | Top Sub - to fit 3.25 in. (8.25 cm) Quick Change Assy. |
| 4* | 0111-332-090 | 6 | O-ring - 90 Duro. |
| 5* | 0111-226-090 | 2 | O-ring - 90 Duro. |
| 6 | 052-5303-003 | 1 | Brass Shear Screw - Approx. 6,500 lb. Shear |
| 7 | WST-3625-121 | 1 | Orifice Sub |
| 8 | WST-3625-125 | 1 | Top Cylinder |
| 9 | WST-3625-522 | 1 | Top Piston |
| 10* | 0111-322-090 | 2 | O-ring - 90 Duro. |
| 11 | WST-3625-126 | 1 | Connector Sub |
| 12* | 0111-335-090 | 1 | O-ring - 90 Duro. |
| 13 | WST-3625-547 | 1 | Bottom Cylinder - High Pressure Tool |
| 14 | WST-3625-130 | 1 | Lock Ring |
| 15 | WST-3625-528 | 1 | Bottom Piston |
| 16 | WST-3625-131 | 1 | Lock Nut |
| 17 | WST-3625-135 | 1 | Assy. - Disc Type Bleeder Valve - Incl. Items 18,19,20 |
| 18 | WST-3625-137 | 1 | Retainer Nut - for Disc Type Bleeder Valve |
| 19* | WST-3625-136 | 1 | Puncture Disc - for Disc Type Bleeder Valve |
| 20* | 0111-213-090 | 1 | O-ring - 90 Duro. - for Disc Type Bleeder Valve |
| 21 | WST-3625-140 | | Rupture Wrench |
| * | WST-3625-110 | | Redress Kit - for WST-3625-501 Incl. Items 2,4,5,6,10,12, 20 |
| * | WST-3625-110D | | Redress Kit - for WST-3625-105 W/Disc Incl. Items 2,4,5,6,10,12,19, 20 |
| | WST-3625-138 | | Rupture Disc Kit - Incl. Items 19 & 20 |

| MAX STROKE | MAX PULL STRENGTH | MAX HYDROSTATIC PRESSURE |
|----------------------|-------------------|--------------------------|
| 10.00 in. (25.40 cm) | 55,000 lb. | 16,000 psi (1,034 bar) |

Power Charges and Igniters referenced at the back of this catalog

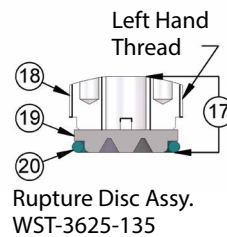
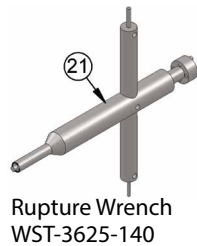

3.63 in. (9.21 cm) O.D. High Pressure Assembly Instructions

1. Install O-rings (4, 10 & 12) . Screw connector sub (11) to either end of top cylinder (8).

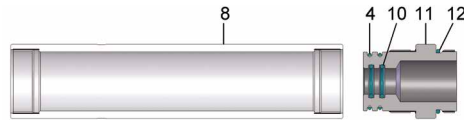

2. Install O-rings (4). Place top piston (9), lower end first, inside top cylinder and connector sub.

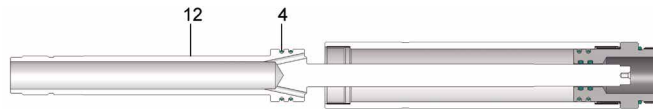

3. Bump top piston fully closed inside top cylinder and connector sub. Bump on wooden block only.

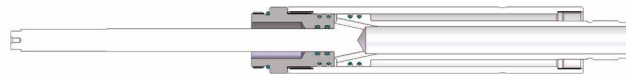

4. Turn tool upright and fill reservoir with motor oil to bottom of threads.

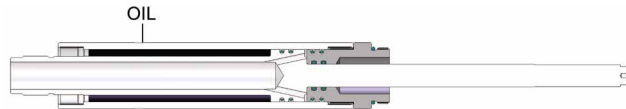

5. Screw orifice sub (7) to top cylinder.

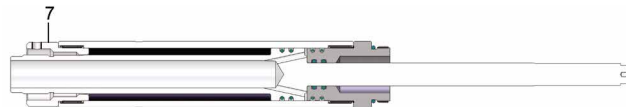

6. Install O-rings (2, 4 & 5). Install rupture disc assembly (17) in top sub (3). Place power charge (open end up) inside top piston. Screw top sub (3) to top piston (9). Do not allow oil to leak out of reservoir.

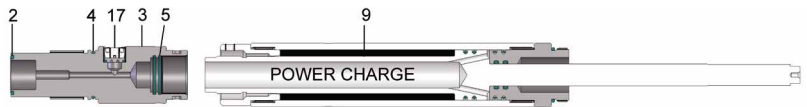

7. Screw bottom cylinder (13) to connector sub (11). Screw lock ring (16) on bottom cylinder.

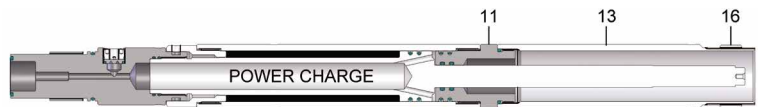

8. Install O-rings (4).Screw bottom piston (15) to top piston. Wrench tighten the top sub, top piston, and bottom piston by holding backup wrench on top sub and tightening bottom piston. Next, rotate top sub until the shear screw (6) can be installed into tapped hole of orifice sub and blind hole provided in top sub. Finally, install igniter assembly and 3-1/4 in. O.D. quick change assembly.

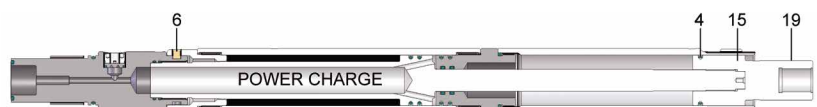

3.63 in. (9.21 cm) O.D. High Pressure Minimum and Maximum Wear Diameters

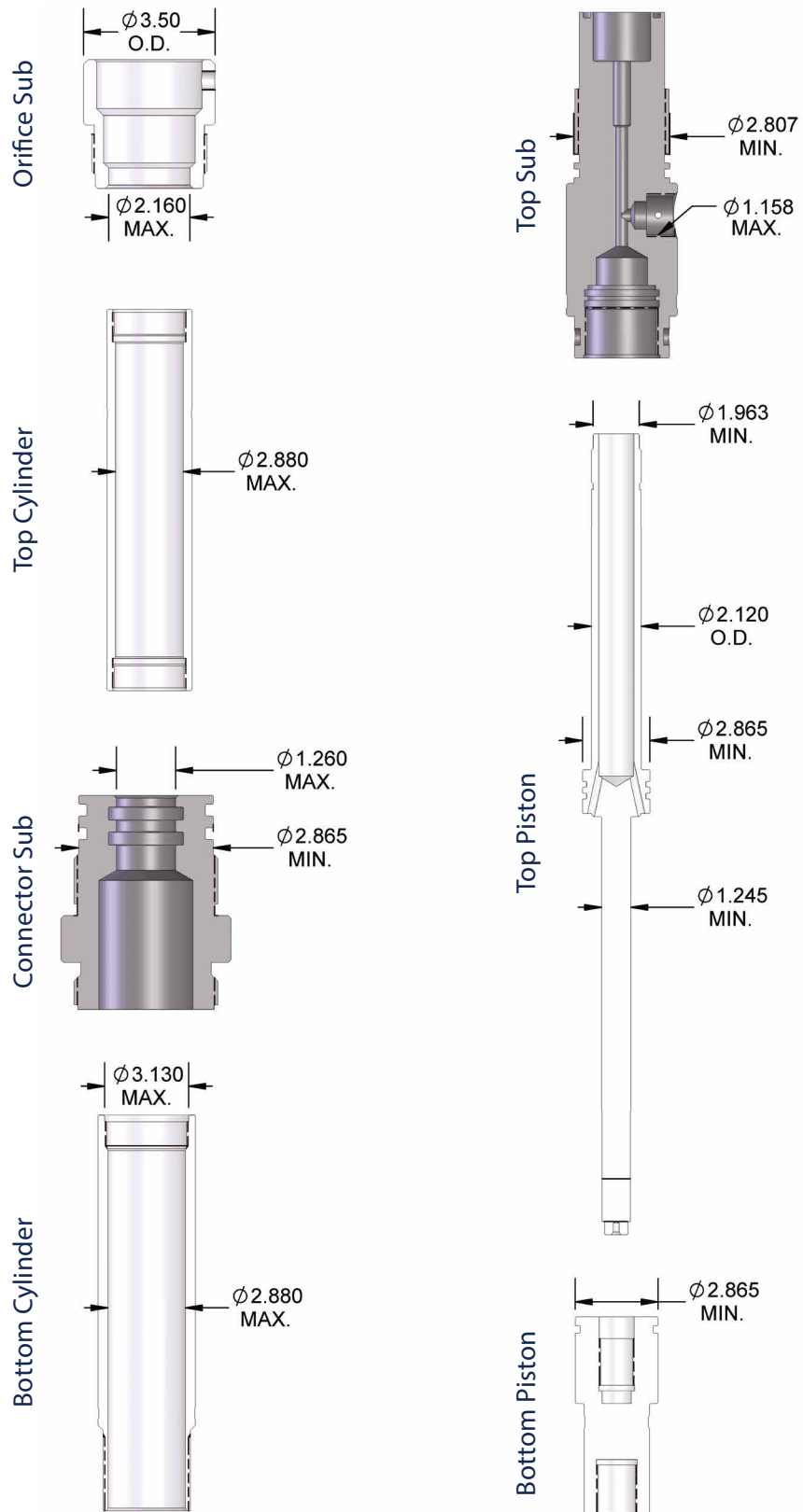

The illustrations shown above list suggested critical minimum and maximum wear diameters.

3.63 in. (9.21 cm) O.D. High Pressure

Pressure Bleeding Procedure

Bleeding through the rupture disc:

1. Rotate the tool so that the bleeder valve/rupture disc port is positioned vertically and the side hole pressure vent is pointed away from you and anyone else. The setting tool contains extremely high pressure gas after the setting action is complete.
2. Slowly thread the bleeder wrench into the retainer nut in a counterclockwise direction until the wrench shoulders up on the retainer nut.
3. Slowly turn the wrench in a clockwise direction until pressure is released through the side vent. This should occur when the bleeder wrench is backed out approximately 0.25 inches (6.35 mm).

CAUTION: DO NOT REMOVE THE BLEEDER WRENCH UNTIL ALL PRESSURE HAS BEEN RELEASED. SERIOUS INJURY CAN OCCUR!

Bleeding through the optional bleeder valve:

1. Rotate the tool so that the bleeder valve/rupture disc port is positioned vertically and the side hole pressure vent is pointed away from you and anyone else. The setting tool contains extremely high pressure gas after the setting action is complete.
2. Using the hex key on the bleeder wrench, slowly turn the valve stem in a counterclockwise direction until pressure is released and the valve stem shoulders on the retainer nut.

CAUTION: DO NOT REMOVE THE RETAINER NUT UNTIL ALL PRESSURE HAS BEEN RELEASED. SERIOUS INJURY CAN OCCUR!

Bleeding procedure at the firing head/top piston:

Hold a backup wrench on the firing head and rotate the top piston about 5 rotations in a counterclockwise direction to release pressure.

CAUTION: DO NOT EXCEED 8 ROTATIONS. SERIOUS INJURY CAN OCCUR!

Bleeding procedure at the quick change/firing head:

Hold a backup wrench on the quick change and rotate the firing head a maximum of 3 rotations in a counterclockwise direction. If pressure does not release, tighten the connection and repeat the procedure.

CAUTION: DO NOT EXCEED 3 ROTATIONS. SERIOUS INJURY CAN OCCUR!

After bleeding disassemble remaining components of the setting tool assembly. Thoroughly clean the components and apply a light coat of oil to prevent rust from forming.

O-ring care and replacement:

All O-rings must be replaced after each use. The O-rings should be lubricated with an appropriate lubricant (we recommend Hydrotex). Use only O-ring kits specifically engineered for Hunting's T-Set tools.

Multi-Stage T-SET®

FEATURES

- Long stroke
- Higher forces necessary for tubing patches
- Options for bleeder valves
- Black oxide coated components
- Ideal for plugs and packers requiring a long stroke
- Bleeder valves provide a safe option to bleed off pressure inside the tool at surface
- Black oxide coating improves corrosion and chemical resistance

BENEFITS

The Multi-Stage T-Set offers the capability to set plugs and packers requiring long setting strokes and higher forces necessary for tubing patches.

A larger slow set power charge is used to compensate for the extra piston movement required for longer strokes. Once ignited, the generated high pressure gas migrates through the upper and lower pistons initiating the setting sequence. Like the Compact Single Stage T-Set, the hydraulic oil slowly bleeds out of the tool providing a cushioning effect. Once the required setting force is achieved, a shear stud breaks releasing the T-Set from the plug/packer.

1.71 in. (4.34 cm) O.D.
1-11/16 in. Multi-Stage Setting Tool

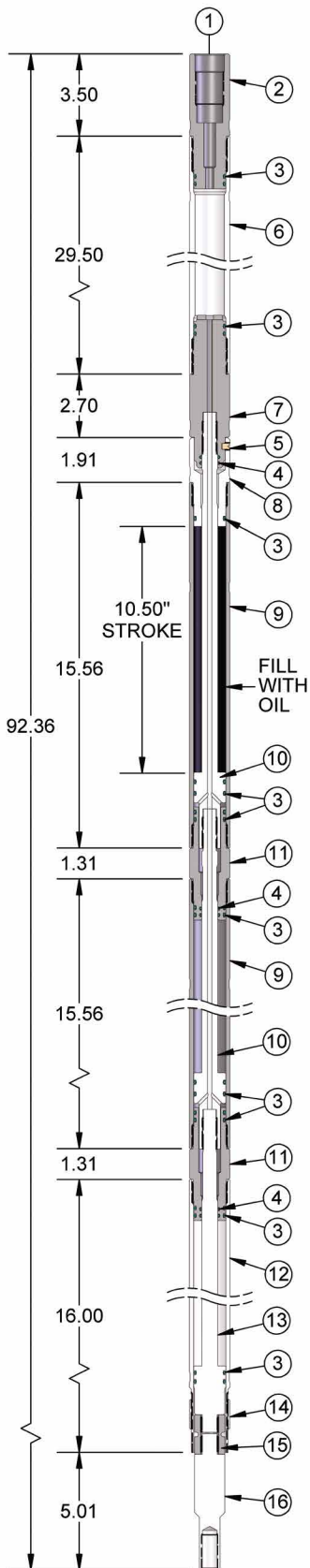

PARTS LIST

| ITEM | PART NUMBER | REQ. | DESCRIPTION |
|--|--------------|------|--|
| 1 | WST-1718-101 | | Assy. - 1.71 in. (4.34 cm) O.D. T-Set® - Top Connection to fit "GO" 1-7/16 in. O.D. High Pressure Firing Head - Incl. Items 2-16 |
| 2 | WST-1718-020 | 1 | Top Sub |
| 3* | 0111-216-090 | 18 | O-ring - 90 Duro. |
| 4* | 0111-115-090 | 6 | O-ring - 90 Duro. |
| 5* | 052-5304-003 | 1 | Brass Shear Screw - Approx. 2,300 lb. Shear |
| 6 | WST-1718-121 | 1 | Power Charge Chamber |
| 7 | WST-1718-028 | 1 | Shear Sub - Non Ported |
| 8 | WST-1718-023 | 1 | Orifice Sub |
| 9 | WST-1718-124 | 2 | Top Cylinder |
| 10 | WST-1718-125 | 2 | Top Piston |
| 11 | WST-1718-126 | 2 | Connector Sub |
| 12 | WST-1718-127 | 1 | Bottom Cylinder |
| 13 | WST-1718-128 | 1 | Bottom Piston |
| 14 | WST-1718-030 | 1 | Lock Ring |
| 15 | WST-1718-130 | 1 | Safety Release Nut - 25,000 lb. Weak Point |
| 16 | WST-1718-131 | 1 | Bottom Adapter |
| * | WST-1718-110 | | Redress Kit - for WST-1718-101 Incl. Items 3,4,5 |
| Optional Equipment Not Included In Assy. WST-1718-101 | | | |
| 17 | WST-1718-022 | 1 | Shear Sub - Ported for Bleeder Valve |
| 18 | WST-Bk05-137 | 1 | Retainer Nut |
| 19 | WST-Bk05-136 | 1 | Rupture Disc |
| 20 | WST-111-090 | 1 | O-ring - 90 Duro |
| 21 | WST-2125-340 | | Rupture Wrench |
| | WST-BK05-138 | | Rupture Disc Kit - Incl. Items 19 & 20 |

| MAX STROKE | MAX PULL STRENGTH | UNPORTED MAX HYDROSTATIC PRESSURE | PORTED MAX HYDROSTATIC PRESSURE |
|----------------------|-------------------|-----------------------------------|---------------------------------|
| 10.50 in. (26.67 cm) | 20,000 lb. | 20,000 psi (1,379 bar) | 15,000 psi (1,034 bar) |

Power Charges and Igniters referenced at the back of this catalog

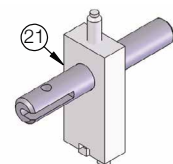

Rupture Wrench
WST-2125-340

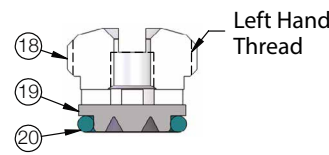

Rupture Disc Assy.
Items 18-20

1.71 in. (4.34 cm) O.D. Assembly Instructions

1. Install O-rings (3), then lubricate O-rings and threads. Slide top pistons (10) in top cylinders (9). Install release nut and bottom adapter (15 & 16) to bottom piston (13). Then install this unit in bottom cylinder (12). Install lock ring (14).

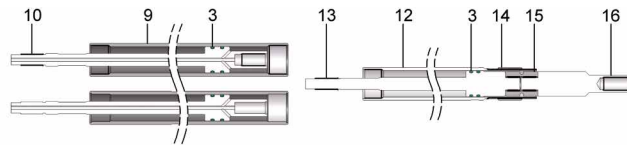

2. Install O-rings (3 & 4). Screw connector subs (11) into bottom cylinder and one of top cylinders. Make wrench tight. Wrench only on wrenching areas provided. Do not wrench on pistons anywhere except in knurled areas.

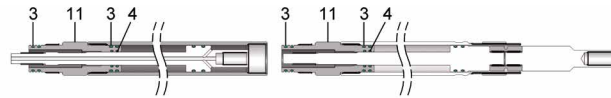

3. Join top cylinder/top piston unit to connector sub/top piston unit. Make wrench tight.



4. Join remaining top cylinder/top piston unit to connector sub/top piston unit. Make wrench tight.

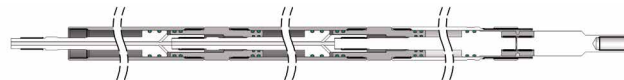

5. Remove tool from vise. Bump tool (view A) completely closed (on wooden block). Next, turn tool upright then fill top cylinder with motor oil until oil level reaches groove at lower end of thread. Install O-ring (3). Install orifice sub (8). Excess oil will purge as sub is screwed in.

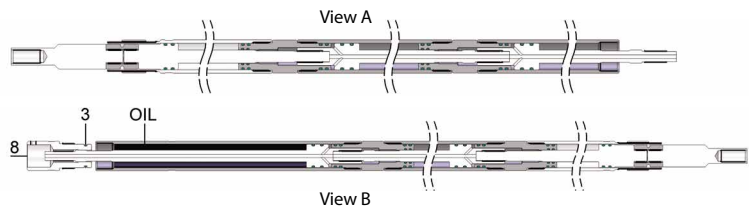

6. Return tool to vise. Make orifice sub (8) wrench tight to top cylinder. Install O-rings (3 & 4). Screw shear sub (7) to top piston. Hold back-up wrench on bottom adapter (16) and tighten shear sub which will ensure all inside connections are tight. Rotate shear sub clockwise until shear screw holes align then install shear screw.

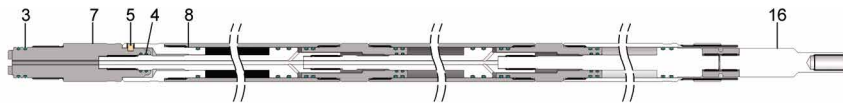

7. Install rupture disc assembly (17) if used. Screw power charge chamber (6) to shear sub (7). Install power charge. Make sure open end of power charge is facing up.



8. Install O-rings (3). Screw top sub (2) to power charge chamber wrench tight. Check igniter by first removing ground wire from contact spring then checking resistance (51 ohms) with blasting galvanometer. Next, wrap ground wire around case of igniter body then place igniter in firing head. Tool is now assembled. Attach appropriate firing adapter, collar locator, and setting adapters.

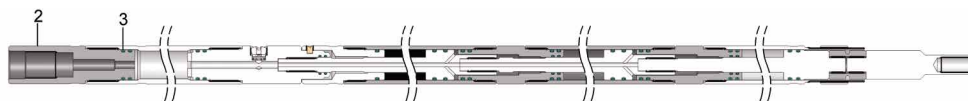

1.71 in. (4.34 cm) O.D. Pressure Bleeding Locations

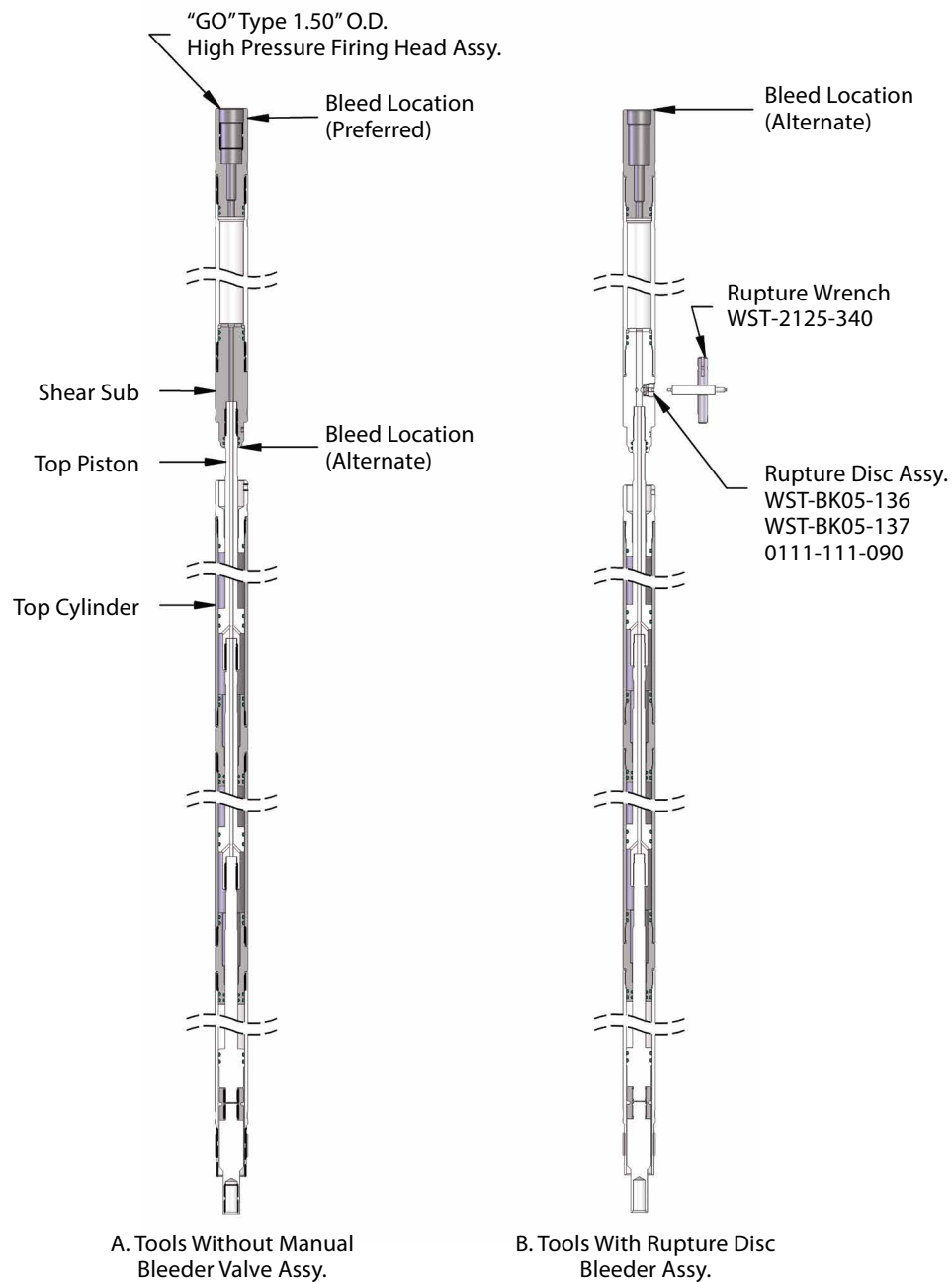

T-Set® wireline multi-stage setting tools in O.D. sizes 1.71 in. (4.34 cm) do not contain a rupture disc bleeder assembly except when specifically ordered.

Two locations for bleeding pressure from tools less rupture disc are illustrated in drawing "A". The preferred method of bleeding pressure is to hold wrench on "GO" 1.50 in. (8.81 cm) O.D. high pressure firing head assembly while turning the setting tool counter clockwise. Pressure will begin to bleed as soon as the lower O-ring on the firing head assembly is uncovered. Ample threads are provided on the firing adapter to prevent separation from cylinder. Should a bridge occur and pressure stops bleeding, screw the tool clockwise then begin the procedure again.

The alternate method shown in drawing "A" is accomplished by holding wrench on shear sub (see parts list) while turning the top cylinder counter clockwise. The top piston will back out of shear sub and pressure will begin to bleed. Again, if a bridge occurs screw the tool clockwise then begin the procedure again.

An indication that most of pressure has safely bled off is when the tool partially closes. This indicates that the trapped compressed atmosphere in the bottom cylinder is overcoming what little gas pressure remains of the power charge.

1.71 in. (4.34 cm) O.D.

Minimum and Maximum Wear Diameters

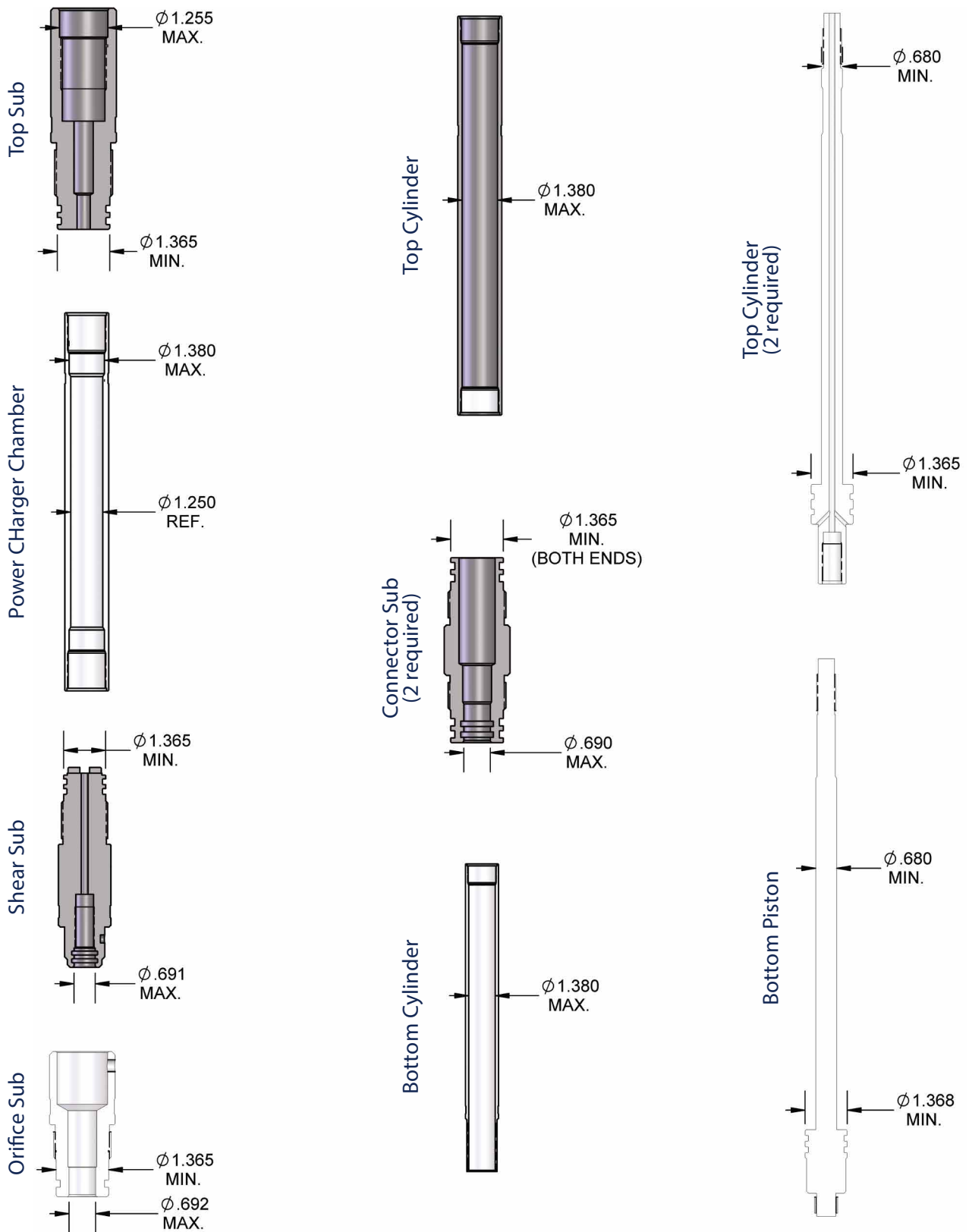

The illustrations shown above list suggested critical minimum and maximum wear diameters.

2.13 in. (5.40 cm) O.D.
2-1/8 in. Multi-Stage Setting Tool

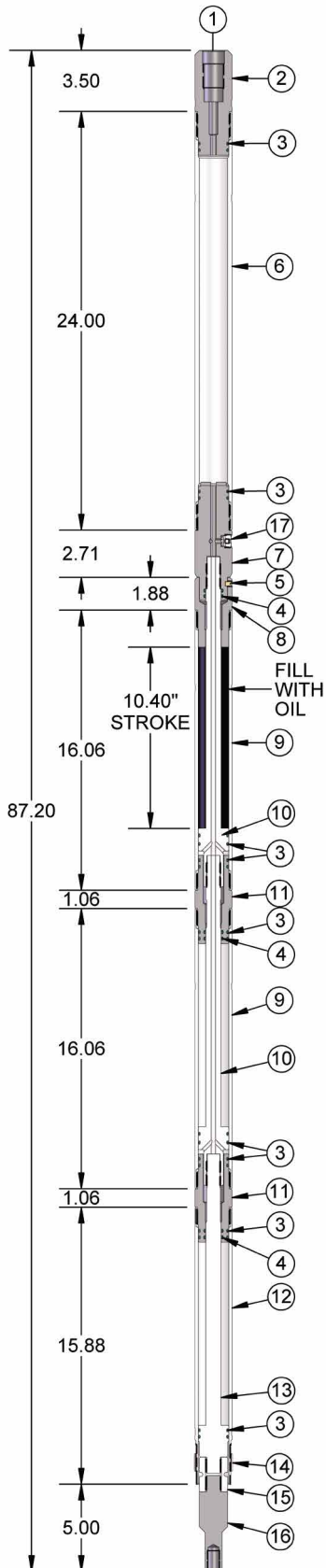

PARTS LIST

| ITEM | PART NUMBER | REQ. | DESCRIPTION |
|------|--------------|------|---|
| 1 | WST-2125-101 | | Assy. - 2.13 in. (5.40 cm) O.D. T-Set* - Top Connection to fit "GO" 1-7/16 in. O.D. High Pressure Firing Head- Incl. Items 2-19 |
| 2 | WST-2125-120 | 1 | Top Sub |
| 3* | 0111-222-090 | 18 | O-ring - 90 Duro. |
| 4* | 0111-212-090 | 6 | O-ring - 90 Duro. |
| 5* | 052-5304-003 | 1 | Brass Shear Screw - Approx. 2,300 lb. Shear |
| 6 | WST-2125-121 | 1 | Power Charge Chamber |
| 7 | WST-2125-122 | 1 | Shear Sub - Ported For Bleeder Valve |
| | WST-2125-132 | | Shear Sub - Unported (No Bleeder Valve) |
| 8 | WST-2125-123 | 1 | Orifice Sub |
| 9 | WST-2125-124 | 2 | Top Cylinder |
| 10 | WST-2125-125 | 2 | Top Piston |
| 11 | WST-2125-126 | 2 | Connector Sub |
| 12 | WST-2125-127 | 1 | Bottom Cylinder |
| 13 | WST-2125-128 | 1 | Bottom Piston |
| 14 | WST-2125-129 | 1 | Lock Ring |
| 15 | WST-2125-130 | 1 | Safety Release Nut- 52,000 lb. Weak Point |
| 16 | WST-2125-131 | 1 | Bottom Adapter |
| 17 | WST-BK05-137 | 1 | Retainer Nut |
| 18 | WST-BK05-136 | 1 | Rupture Disc |
| 19* | 0111-111-090 | 1 | O-ring - 90 Duro |
| 20 | WST-2125-340 | 1 | Rupture Wrench |
| * | WST-2125-110 | | Redress Kit - for WST-2125-101 Incl. Items 3,4,5,18 & 19 |
| | WST-BK05-138 | | Rupture Disc Kit - Incl. Items 18 & 19 |

| MAX STROKE | MAX PULL STRENGTH | UNPORTED MAX HYDROSTATIC PRESSURE | PORTED MAX HYDROSTATIC PRESSURE |
|----------------------|-------------------|-----------------------------------|---------------------------------|
| 10.40 in. (26.42 cm) | 32,000 lb. | 20,000 psi (1,379 bar) | 15,000 psi (1,034 bar) |

Power Charges and Igniters referenced at the back of this catalog

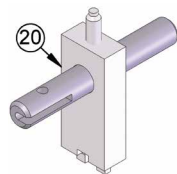

Rupture Wrench
WST-2125-340

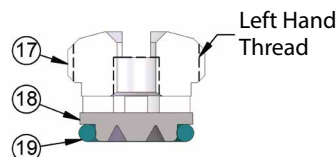

Rupture Disc Assy.
Items 18-20

2.13 in. (5.40 cm) O.D. Assembly Instructions

1. Install O-rings (3), then lubricate O-rings and threads. Slide top pistons (10) in top cylinders (9). Install release nut and bottom adapter (15 & 16) to bottom piston (13). Then install this unit in bottom cylinder (12). Install lock ring (14).

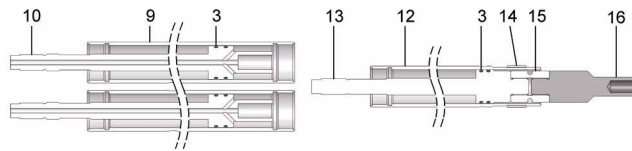

2. Install O-rings (3 & 4). Screw connector subs (11) into bottom cylinder and one of top cylinders. Make wrench tight. Wrench only on wrenching areas provided. Do not wrench on pistons anywhere except in knurled areas.

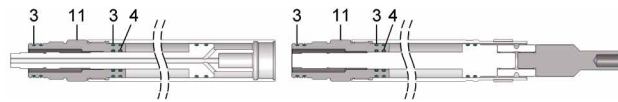

3. Join top cylinder/top piston unit to connector sub/top piston unit. Make wrench tight.

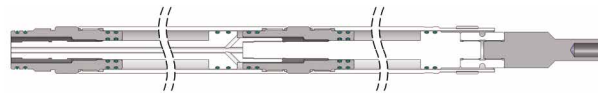

4. Join remaining top cylinder/top piston unit to connector sub/top piston unit. Make wrench tight.

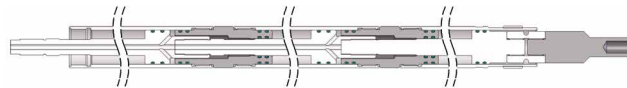

5. Remove tool from vise. Bump tool (view A) completely closed (on wooden block). Next, turn tool upright then fill top cylinder with motor oil until oil level reaches groove at lower end of thread. Install orifice sub (8). Excess oil will purge as sub is screwed in.

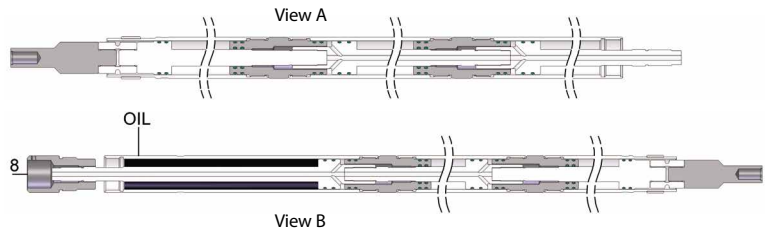

6. Return tool to vise. Make orifice sub (8) wrench tight to top cylinder. Install O-rings (3 & 4). Screw shear sub (7) to top piston. Hold back-up wrench on bottom adapter (16) and tighten shear sub which will ensure all inside connections are tight. Rotate shear sub clockwise until shear screw holes align then install shear screw (5).

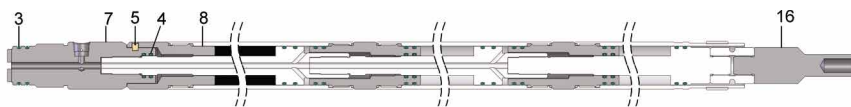

7. Install rupture disc assembly (17) if used. Screw power charge chamber (6) to shear sub (7). Install power charge. Make sure open end of power charge is facing up.

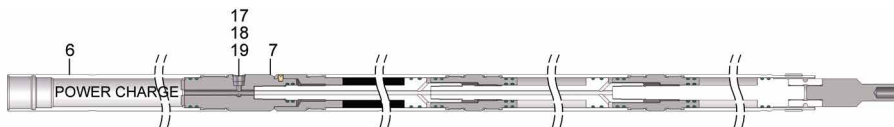

8. Install O-rings (3). Screw top sub (2) to power charge chamber wrench tight. Check igniter by first removing ground wire from contact spring then checking resistance (51 ohms) with blasting galvanometer. Next, wrap ground wire around case of igniter body then place igniter in firing head. Tool is now assembled. Attach appropriate firing adapter, collar locator, and setting adapters.

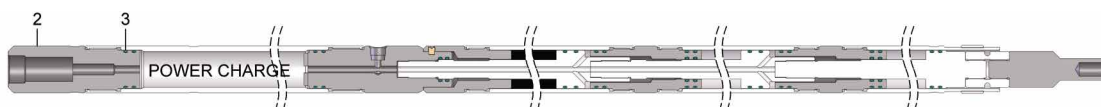

2.13 in. (5.40 cm) O.D. Pressure Bleeding Locations

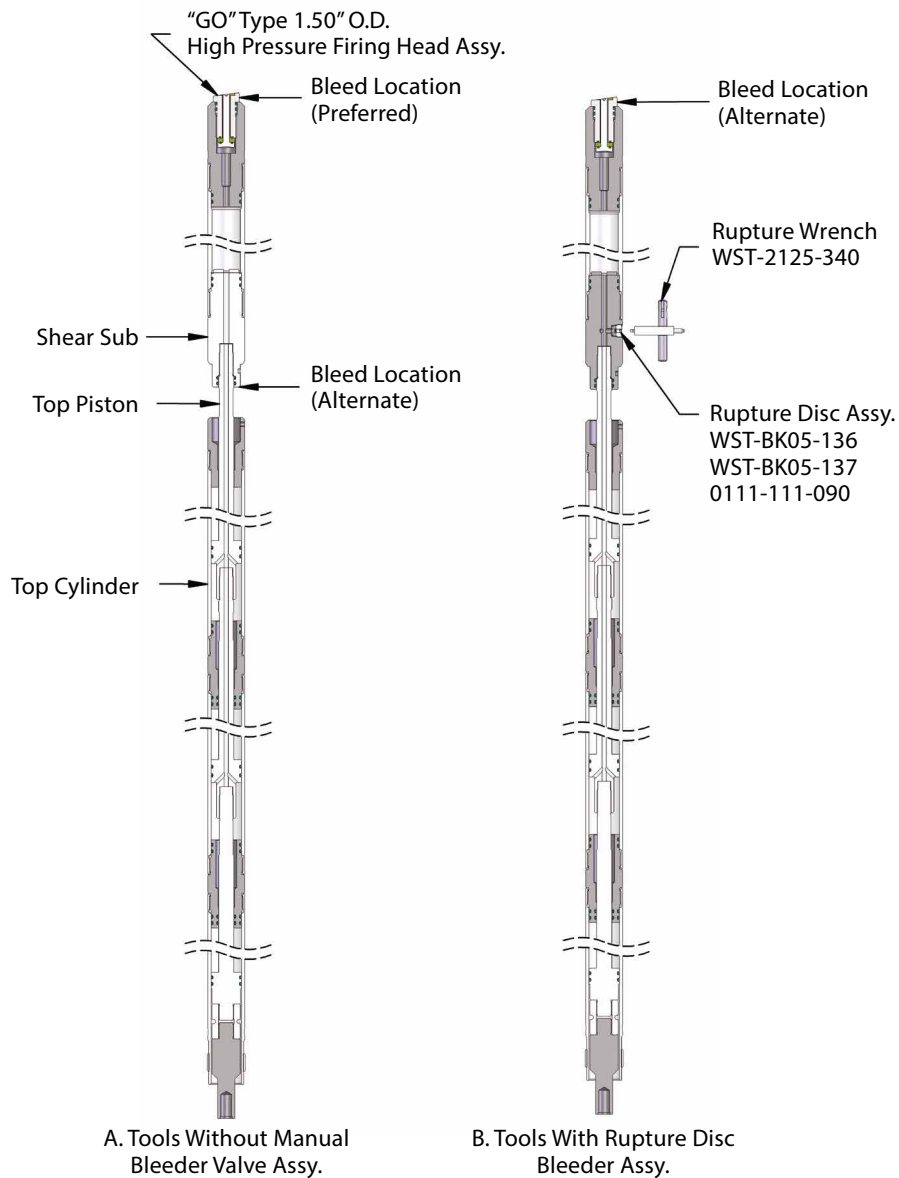

T-Set® wireline multi-stage setting tools in O.D. sizes 2.13 in. (5.40 cm) contain a rupture disc bleeder assembly except when specifically ordered with a non ported shear sub for a manual bleed application.

Two locations for bleeding pressure from tools less rupture disc are illustrated in drawing "A". The preferred method of bleeding pressure is to hold wrench on "GO" 1.50 in. O.D. high pressure firing head assembly while turning the setting tool counter clockwise. Pressure will begin to bleed as soon as the lower O-ring on the firing head assembly is uncovered. Ample threads are provided on the firing adapter to prevent separation from cylinder. Should a bridge occur and pressure stops bleeding, screw the tool clockwise then begin the procedure again.

The alternate method shown in drawing "A" is accomplished by holding wrench on shear sub (see parts list) while turning the top cylinder counter clockwise. The top piston will back out of shear sub and pressure will begin to bleed. Again, if a bridge occurs screw the tool clockwise then begin the procedure again.

When using a ported assembly, position the tool so that the rupture port of the ported shear sub is facing "away" from the operator. (Drawing B). Take the WST-2125-340 rupture wrench, screw the "left hand" thread of the rupture stem into the "left hand" threads of the WST-BK05-137 retainer nut until the stem bottoms out on the surface of the WST-BK05-136 rupture disc. Grasp the wrench firmly and turn counter clockwise until the rupture disc is punctured and all pressure is bled from the tool. Should a bridge occur, refer to alternative bleed location and instructions.

An indication that most of pressure has safely bled off is when the tool partially closes. This indicates that the trapped compressed atmosphere in the bottom cylinder is overcoming what little gas pressure remains of the power charge.

2.13 in. (5.40 cm) O.D.

Minimum and Maximum Wear Diameters

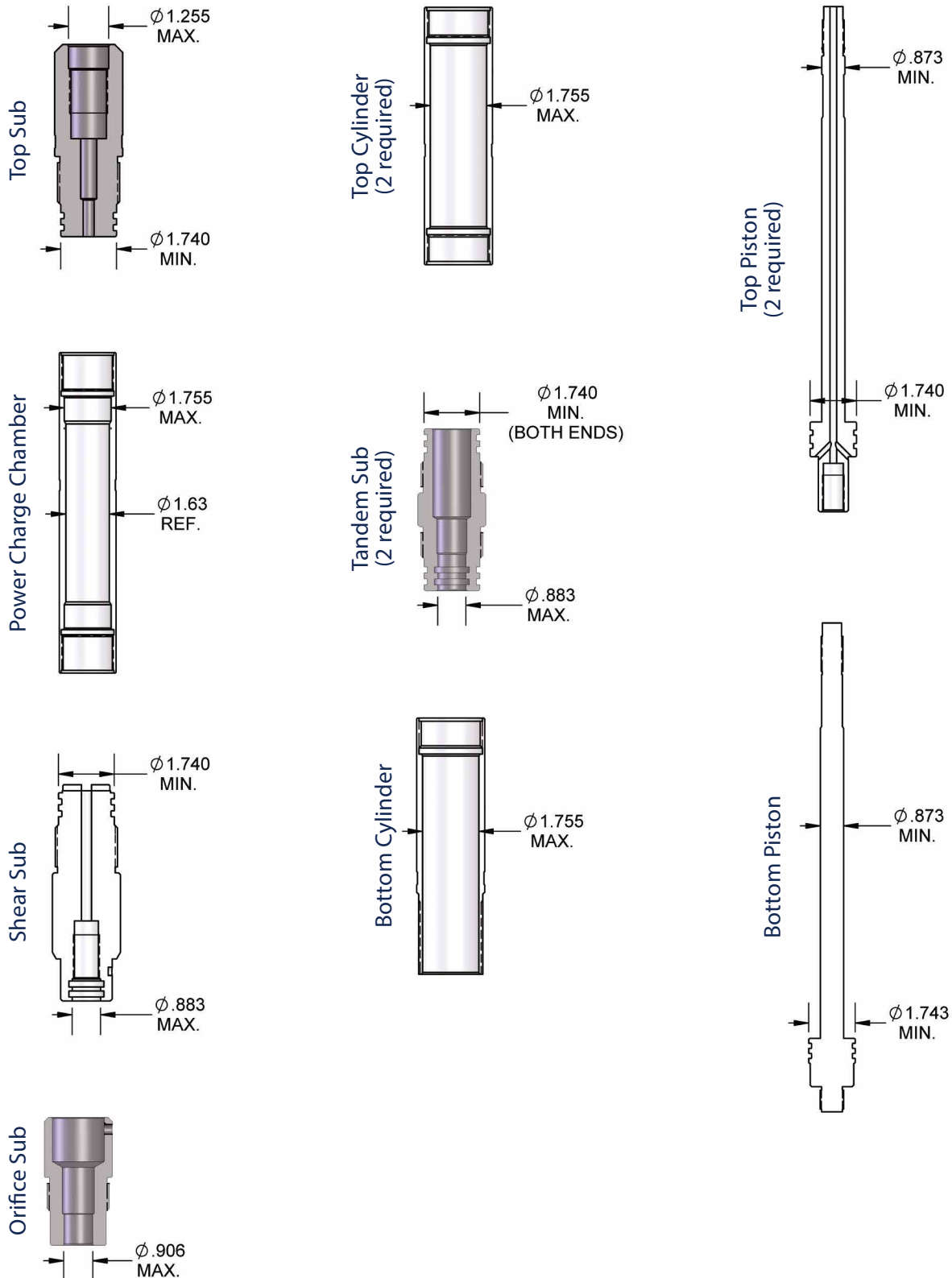

The illustrations shown above list suggested critical minimum and maximum wear diameters.

3.25 in. (8.25 cm) O.D. 3-1/4 in. Multi-Stage Setting Tool

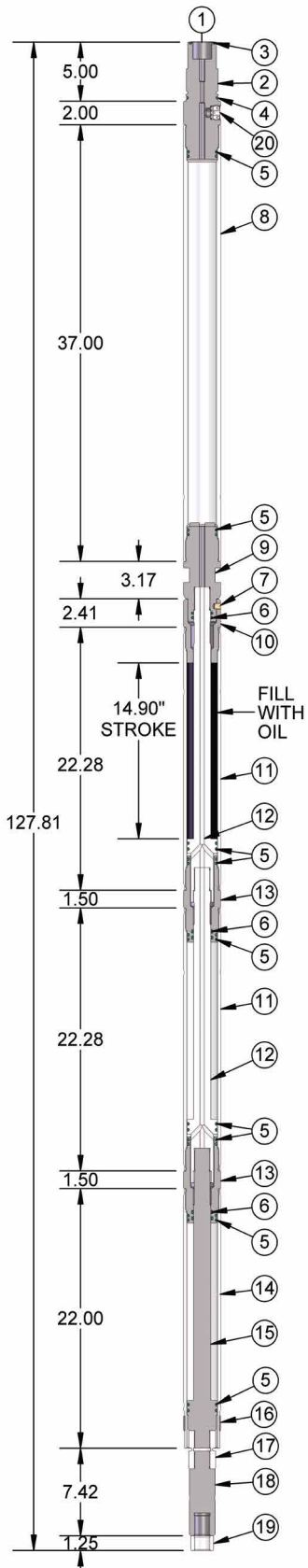

PARTS LIST

| ITEM | PART NUMBER | REQ. | DESCRIPTION |
|------|--------------|------|---|
| 1 | WST-3250-001 | | Assy. - 3.25 in. (8.25 cm) O.D. T-Set® - Top Connection to fit "GO" 3.25 in. (8.25 cm) O.D. Quick Change Assy. - Incl. Items 2-23 |
| 2 | WST-3250-020 | 1 | Top Sub - Ported for Bleeder Valve |
| 3* | 0111-328-090 | 1 | O-ring - 90 Duro. |
| 4* | 0111-332-090 | 1 | O-ring - 90 Duro. |
| 5* | 0111-331-090 | 18 | O-ring - 90 Duro. |
| 6* | 0111-325-090 | 6 | O-ring - 90 Duro. |
| 7* | 052-5303-003 | 1 | Brass Shear Screw - Approx. 2,300 lb. Shear |
| 8 | WST-3250-021 | 1 | Power Charge Chamber |
| 9 | WST-3250-022 | 1 | Shear Sub |
| 10 | WST-3250-023 | 1 | Orifice Sub |
| 11 | WST-3250-024 | 2 | Top Cylinder |
| 12 | WST-3250-025 | 2 | Top Piston |
| 13 | WST-3250-026 | 2 | Connector Sub |
| 14 | WST-3250-027 | 1 | Bottom Cylinder |
| 15 | WST-3250-028 | 1 | Bottom Piston |
| 16 | WST-3250-029 | 1 | Lock Ring |
| 17 | WST-3250-030 | 1 | Safety Release Nut - 120,000 Lb. Weak Point |
| 18 | WST-3250-031 | 1 | Bottom Adapter |
| 19 | WST-3625-131 | 1 | Lock Nut |
| 20 | WST-3625-135 | 1 | Assy. - Disc Type Bleeder Valve - Incl. Items 21,22,23 |
| 21 | WST-3625-137 | 1 | Retainer Nut - for Disc Type Bleeder Valve |
| 22* | WST-3625-136 | 1 | Puncture Disc - for Disc Type Bleeder Valve |
| 23* | 0111-213-090 | 1 | O-ring - 90 Duro. |
| 24 | WST-3625-140 | | Rupture Wrench |
| * | WST-3250-010 | | Redress Kit - for WST-3250-001 Incl. Items 3,4,5,6,7,22,23 |
| | WST-3625-138 | | Rupture Disc Kit - Incl. Items 22 & 23 |

| MAX STROKE | MAX PULL STRENGTH | PORTED MAX HYDROSTATIC PRESSURE |
|----------------------|-------------------|---------------------------------|
| 14.90 in. (37.85 cm) | 72,000 lb. | 15,000 psi (1,034 bar) |

Power Charges and Igniters referenced at the back of this catalog

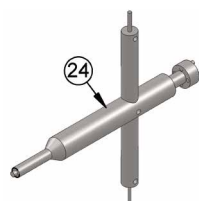

Rupture Wrench
WST-3625-140

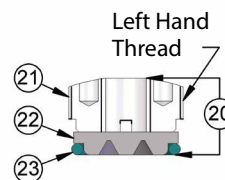

Rupture Disc Assy.
Items 21-23

3.25 in. (8.25 cm) O.D. Assembly Instructions

1. Install O-rings (5), then lubricate O-rings and threads. Slide top pistons (12) in top cylinders (11). Install release nut and bottom adapter (17 & 18) to bottom piston (15). Then install this unit in bottom cylinder (14). Install lock ring (16).

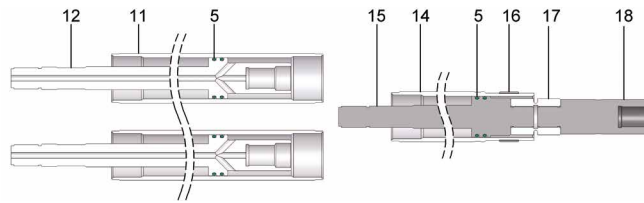

2. Install O-rings (5 & 6). Screw connector subs (13) into bottom cylinder and one of top cylinders. Make wrench tight. Wrench only on wrenching areas provided. Do not wrench on pistons anywhere except in knurled areas.

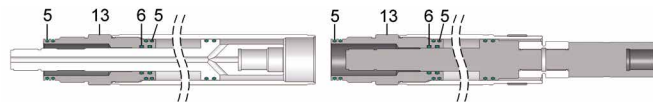

3. Join top cylinder/top piston unit to connector sub/top piston unit. Make wrench tight.

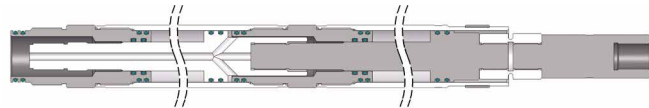

4. Join remaining top cylinder/top piston unit to connector sub/top piston unit. Make wrench tight.

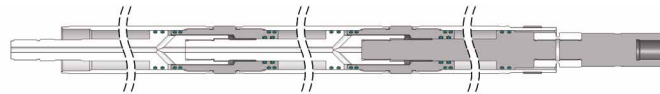

5. Remove tool from vise. Bump tool (view A) completely closed (on wooden block). Next, turn tool upright then fill top cylinder with motor oil until oil level reaches groove at lower end of thread. Install orifice sub (10). Excess oil will purge as sub is screwed in.

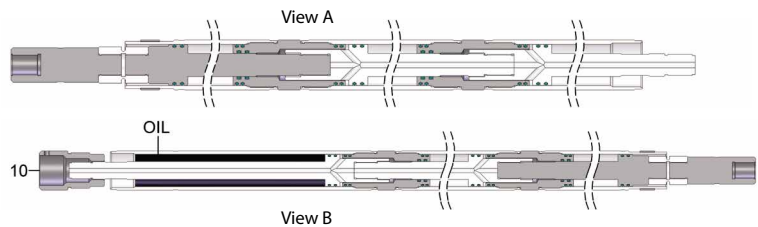

6. Install O-rings (5 & 6). Return tool to vise. Make orifice sub (10) wrench tight to top cylinder screw shear sub (9) to top piston. Hold back-up wrench on bottom adapter (18) and tighten shear sub which will ensure all inside connections are tight. Rotate shear sub clockwise until shear screw holes align then install shear screw (7).

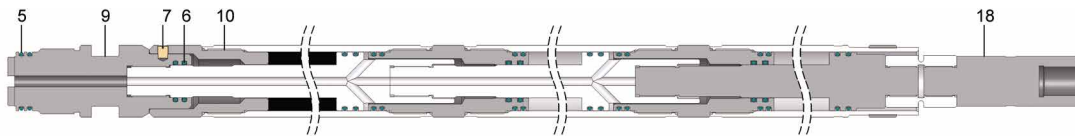

7. Install rupture disc assembly (20). Screw power charge chamber (8) to shear sub (9). Install power charge. Make sure open end of power charge is facing up.

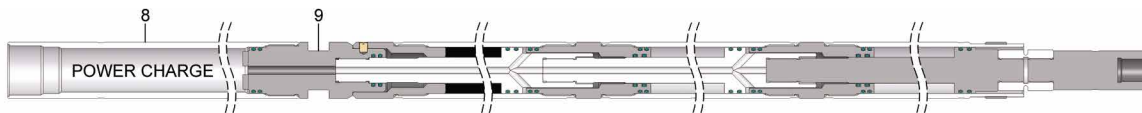

8. Install O-rings (5). Screw top sub (2) to power charge chamber wrench tight. Check igniter by first removing ground wire from contact spring then checking resistance (51 ohms) with blasting galvanometer. Next, wrap ground wire around case of igniter body then place igniter in firing head. Tool is now assembled. Attach appropriate firing adapter, collar locator, and setting adapters.

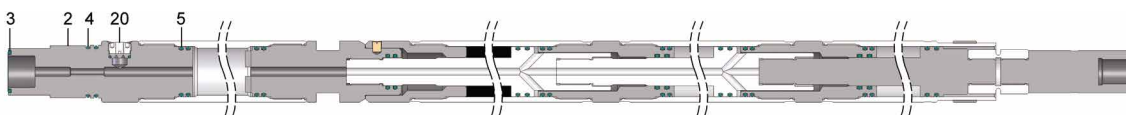

3.25 in. (8.25 cm) O.D. Pressure Bleeding Locations

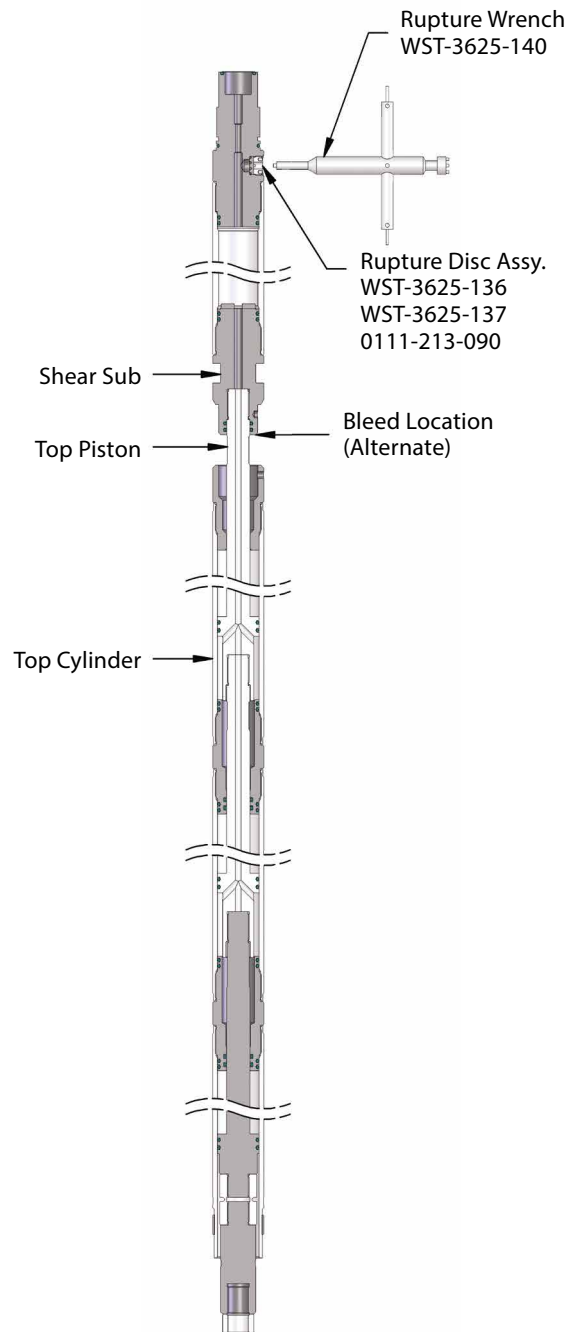

Position tool so that the rupture port in the top sub is facing "away" from the operator. Take the WST-3625-140 rupture wrench, screw the "left hand" threads of the rupture stem into the "left hand" thread of the WST-3625-137 retainer nut until the stem bottoms out on the face of the WST-3625-136 rupture disc. Grasp the wrench firmly and turn counter clockwise until the rupture disc is punctured and all pressure is bled from the tool. Should a bridge occur, refer to alternate bleed locations and instruction.

The alternate method shown is accomplished by holding wrench on the shear sub (see parts list) while turning the top cylinder counter clockwise. The top piston will back out of the shear sub and pressure will begin to bleed. Again, if a bridge occurs screw the tool clockwise then begin the procedure again.

An indication that most of pressure has safely bled off is when the tool partially closes. This indicates that the trapped compressed atmosphere in the bottom cylinder is overcoming what little gas pressure remains of the power charge.

4.50 in. (11.43 cm) O.D. 4-1/2 in. Multi-Stage Setting Tool

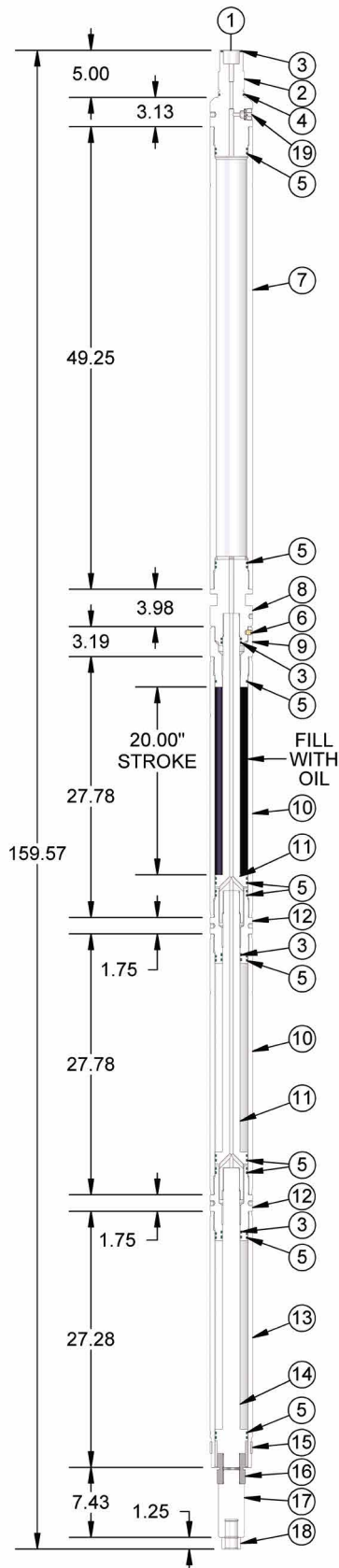

PARTS LIST

| ITEM | PART NUMBER | REQ. | DESCRIPTION |
|------|--------------|------|--|
| 1 | WST-4500-001 | | Assy. - 4.50 in. (11.43 cm) O.D. T-Set [®] - Top Connection to fit "GO" 3.25 in. (8.25 cm) O.D. Quick Change Assy. - Incl. Items 2-22 |
| 2 | WST-4500-020 | 1 | Top Sub - Ported for Bleeder Valve |
| 3* | 0111-328-090 | 7 | O-ring - 90 Duro. |
| 4* | 0111-332-090 | 1 | O-ring - 90 Duro. |
| 5* | 0111-338-090 | 19 | O-ring - 90 Duro. |
| 6* | 052-5303-003 | 1 | Brass Shear Screw - Approx. 2,300 lb. Shear |
| 7 | WST-4500-021 | 1 | Power Charge Chamber |
| 8 | WST-4500-022 | 1 | Shear Sub |
| 9 | WST-4500-023 | 1 | Orifice Sub |
| 10 | WST-4500-024 | 2 | Top Cylinder |
| 11 | WST-4500-025 | 2 | Top Piston |
| 12 | WST-4500-026 | 2 | Connector Sub |
| 13 | WST-4500-027 | 1 | Bottom Cylinder |
| 14 | WST-4500-028 | 1 | Bottom Piston |
| 15 | WST-4500-029 | 1 | Lock Ring |
| 16 | WST-4500-030 | 1 | Safety Release Nut - 194,000 lb. Weak Point |
| 17 | WST-4500-031 | 1 | Bottom Adapter |
| 18 | WST-3625-131 | 1 | Lock Nut |
| 19 | WST-3625-135 | 1 | Assy. - Disc Type Bleeder Valve - Items 20,21,22 |
| 20 | WST-3625-137 | 1 | Retainer Nut - for Disc Type Bleeder Valve |
| 21* | WST-3625-136 | 1 | Puncture Disc - for Disc Type Bleeder Valve |
| 22* | 0111-213-090 | 1 | O-ring - 90 Duro. |
| 23 | WST-3625-140 | | Rupture Wrench |
| * | WST-4500-010 | | Redress Kit - for WST-4500-001 Incl. Items 3,4,5,6,21,22 |
| | WST-3625-138 | | Rupture Disc Kit - Incl. Items 21 & 22 |

| MAX STROKE | MAX PULL STRENGTH | PORTED MAX HYDROSTATIC PRESSURE |
|--------------------|-------------------|---------------------------------|
| 20.0 in. (50.8 cm) | 95,000 lb. | 15,000 psi (1,034 bar) |

Power Charges and Igniters referenced at the back of this catalog

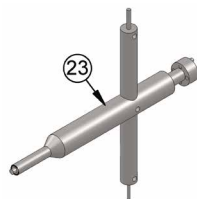

Rupture Wrench
WST-3625-140

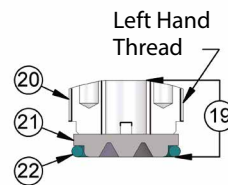

Rupture Disc Assy.
Items 20-22

4.50 in. (11.43 cm) O.D. Multi-Stage Assembly Instructions

1. Install O-rings (5). Then lubricate O-rings and threads. Slide top pistons (11) in top cylinders (10). Install release nut and bottom adapter (16 & 17) to bottom piston (14). Then install this unit in bottom cylinder (13). Install lock ring (15).

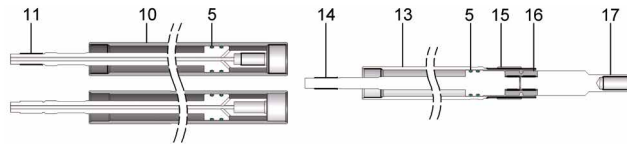

2. Install O-rings (5). Screw connector subs (12) into bottom cylinder and one of top cylinders. Make wrench tight. Wrench only on wrenching areas provided. Do not wrench on pistons anywhere except in knurled areas.

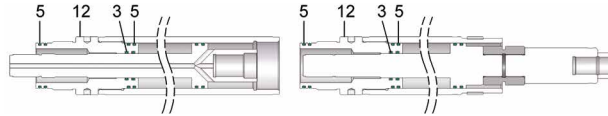

3. Join top cylinder/top piston unit to connector sub/top piston unit. Make wrench tight.

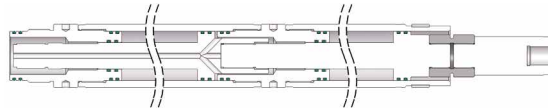

4. Join remaining top cylinder/top piston unit to connector sub/top piston unit. Make wrench tight.

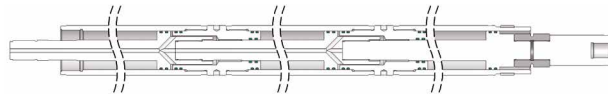

5. Remove tool from vise. Bump tool (view A) completely closed (on wooden block). Next, turn tool upright then fill top cylinder with motor oil until oil level reaches groove at lower end of thread. Install O-rings (5), orifice sub (9). Excess oil will purge as sub is screwed in.

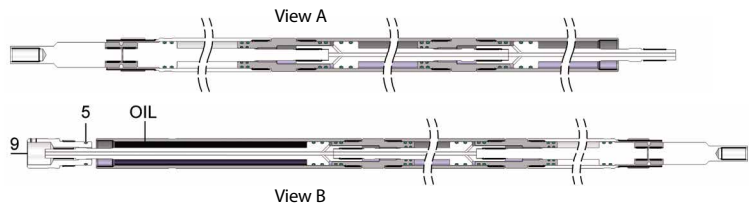

6. Return tool to vise. Install O-rings (3 & 5). Make orifice sub (9) wrench tight to top cylinder screw shear sub (7) to top piston. Hold back-up wrench on bottom adapter (16) and tighten shear sub which will ensure all inside connections are tight. Rotate shear sub clockwise until shear screw holes align then install shear screw.

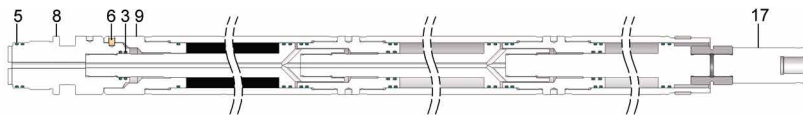

7. Install rupture disc assembly (19). Screw power charge chamber (7) to shear sub (8). Install power charge. Make sure open end of power charge is facing up.

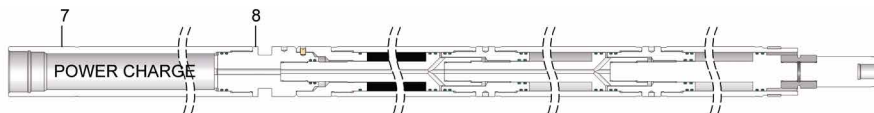

8. Install O-rings (5). Screw top sub (2) to power charge chamber wrench tight. Check igniter by first removing ground wire from contact spring then checking resistance (51 ohms) with blasting galvanometer. Next, wrap ground wire around case of igniter body then place igniter in firing head. Tool is now assembled. Attach appropriate firing adapter, collar locator, and setting adapters.

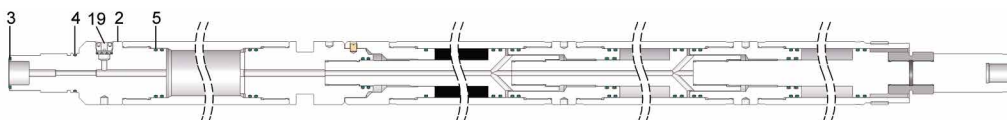

4.50 in. (11.43 cm) O.D. Pressure Bleeding Locations

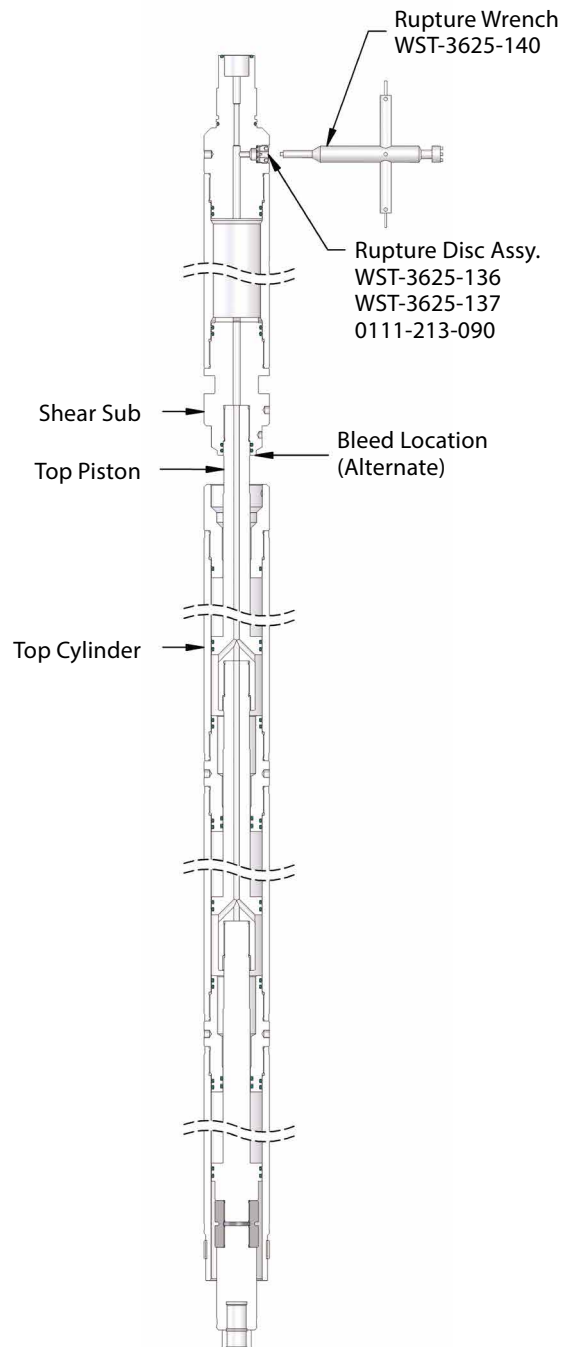

Position tool so that the rupture port in the top sub is facing "away" from the operator. Take the WST-3625-140 rupture wrench, screw the "left hand" threads of the rupture stem into the "left hand" thread of the WST-3625-137 retainer nut until the stem bottoms out on the face of the WST-3625-136 rupture disc. Grasp the wrench firmly and turn counter clockwise until the rupture disc is punctured and all pressure is bled from the tool. Should a bridge occur, refer to alternate bleed locations and instruction.

The alternate method shown is accomplished by holding wrench on shear sub (see parts list) while turning the top cylinder counter clockwise. The top piston will back out of shear sub and pressure will begin to bleed. Again, if a bridge occurs screw the tool clockwise then begin the procedure again.

An indication that most of pressure has safely bled off is when the tool partially closes. This indicates that the trapped compressed atmosphere in bottom cylinder is overcoming what little gas pressure remains of the power charge.

4.50 in. (11.43 cm) O.D.
Minimum and Maximum Wear Diameters

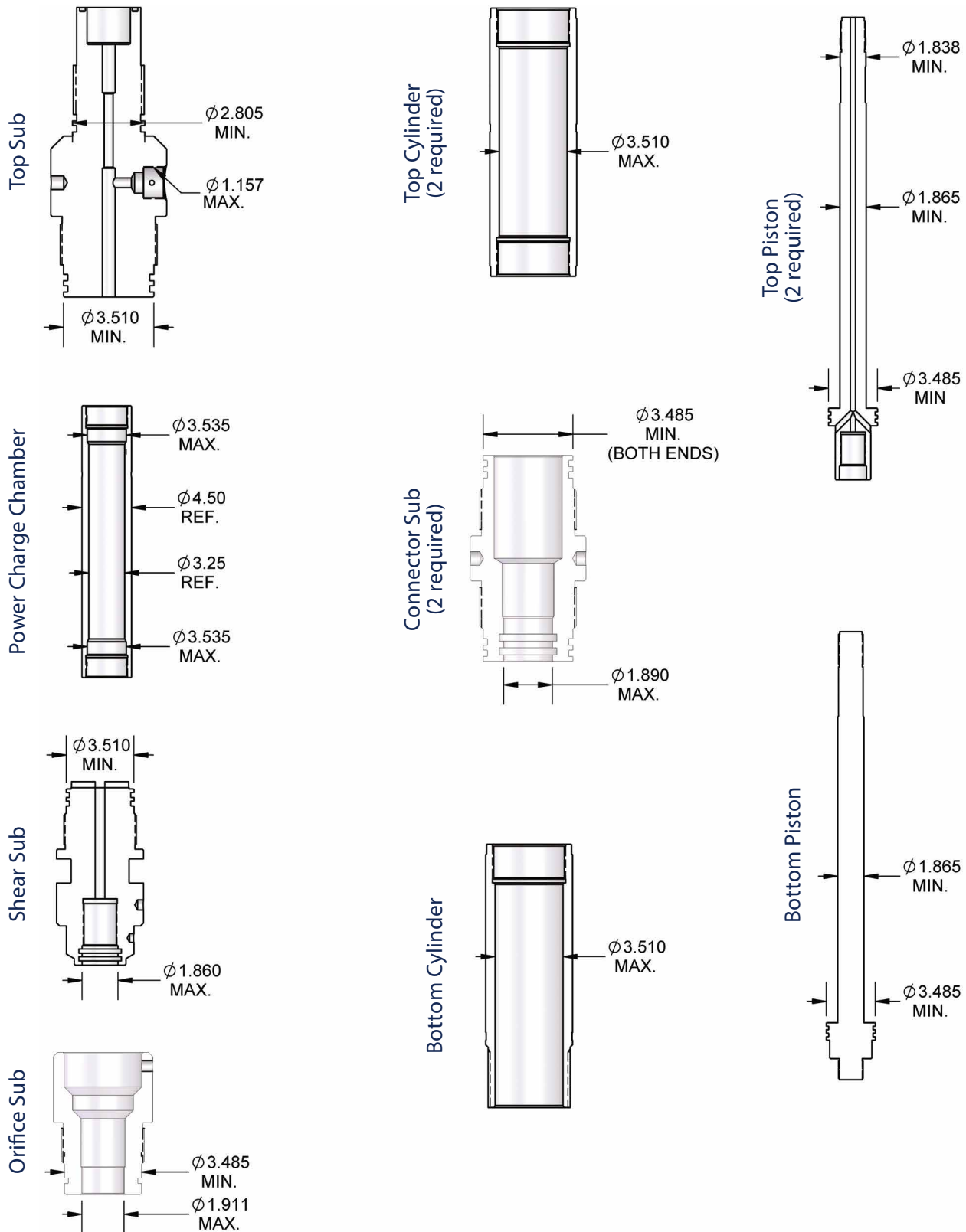

The illustrations shown above list suggested critical minimum and maximum wear diameters.

Size 05 – 10 – 20 T-SET®

FEATURES

- Case hardened pressure cylinders
- Black oxide coated components
- Options for bleeder valves

BENEFITS

- Greater surface hardness and increased abrasive wear from case hardening
- Black oxide coating improves corrosion and chemical resistance
- Bleeder valves provide a safer option to bleed off pressure inside the tool at surface

The Size 05 – 10 – 20 T-Set series features a classic design that the oilfield has been familiar with for decades. Hunting has made many improvements to the original design, making it the most rugged and reliable setting tool in the oilfield today.

The ignition of a power charge creates high gas pressure inside the setting tool. The generated high pressure gas pushes a piston, which in turn drives hydraulic oil through a small orifice, initiating the setting sequence. Once the required setting force is achieved, a shear stud breaks releasing the T-Set from the plug/packer.

T-Set® Size 05

Setting tool

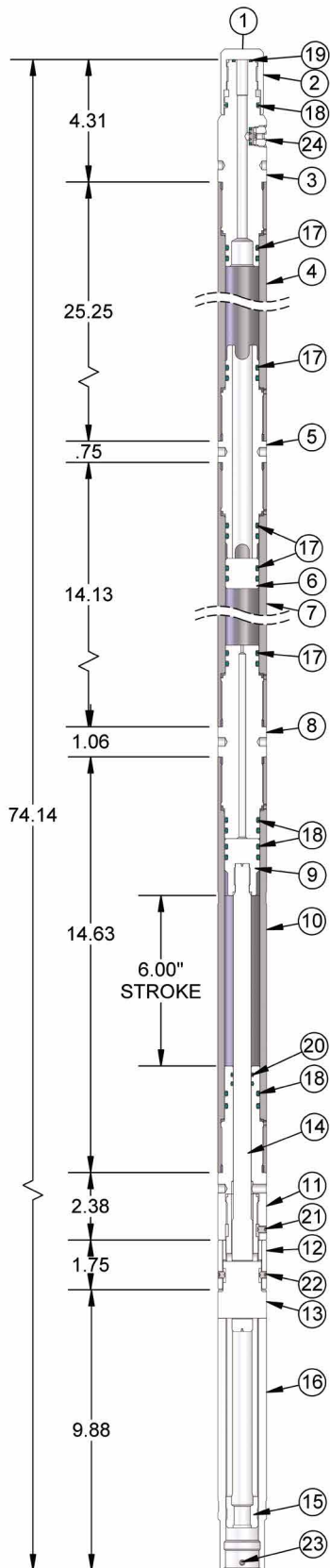

PARTS LIST

| ITEM | PART NUMBER | REQ. | DESCRIPTION |
|------|-------------------|------|--|
| 1 | WST-BK05-001 | | Assy. - 1.71 in. (4.34 cm) O.D. Size 05 T-Set® - Incl. Items 2-26 |
| 2 | WST-BK05-036 | 1 | Thread Protector |
| 3 | WST-BK05-020 | 1 | Power Charge Chamber |
| 4 | WST-BK05-021 | 1 | Upper Cylinder |
| 5 | WST-BK05-023 | 1 | Tandem Connector |
| 6 | WST-BK05-022 | 1 | Upper Piston |
| 7 | WST-BK05-034 | 1 | Middle Cylinder |
| 8 | WST-BK05-025 | 1 | Middle Connector |
| 9 | WST-BK05-024 | 1 | Lower Piston |
| 10 | WST-BK05-035 | 1 | Lower Cylinder |
| 11 | WST-BK05-027 | 1 | Lower Connector |
| 12 | WST-BK05-029 | 1 | Link Retaining Ring |
| 13 | WST-BK05-031 | 1 | Crosslink |
| 14 | WST-BK05-026 | 1 | Piston Rod |
| 15 | WST-BK05-030 | 1 | Setting Mandrel |
| 16 | WST-BK05-028 | 1 | Crosslink Sleeve |
| 17* | 0111-213-090 | 10 | O-ring - 90 Duro. |
| 18* | 0111-214-090 | 7 | O-ring - 90 Duro. |
| 19* | 0111-112-090 | 1 | O-ring - 90 Duro. |
| 20* | 0111-114-090 | 2 | O-ring - 90 Duro. |
| 21 | CPSS-0025-20-0031 | 1 | Cup Point Set Screw - 1/4-20 X 5/16 lg. |
| 22 | CPSS-0025-20-0025 | 2 | Cup Point Set Screw - 1/4-20 X 1/4 lg. |
| 23 | CPSS-0025-20-0019 | 1 | Cup Point Set Screw - 1/4-20 X 3/16 lg. |
| 24 | WST-BK05-137 | 1 | Retainer Nut |
| 25* | WST-BK05-136 | 1 | Rupture Disc |
| 26* | 0111-111-090 | 1 | O-ring - 90 Duro. |
| 27 | WST-2125-340 | | Rupture Wrench |
| * | WST-BK05-010 | | Redress Kit - for WST-BK05-001 Incl. Items 17, 18, 19, 20, 25 & 26 |
| | WST-BK05-138 | | Rupture Disc Kit - Incl. Items 25 & 26 |

| SIZE | MAX O.D. | MAX STROKE | MAX PULL STRENGTH |
|------|----------------------|-------------------|-------------------|
| 05 | 1.718 in. (4.364 cm) | 6.0 in. (15.2 cm) | 10,000 lb. |

Power Charges and Igniters referenced at the back of this catalog

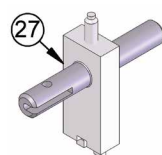

Rupture Wrench
WST-2125-340

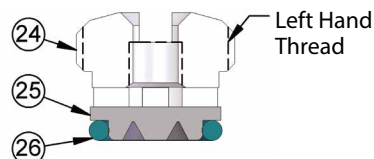

Rupture Disc Assy.
WST-BK05-135
Items 24, 25 & 26

T-Set® Size 05 Assembly Instructions

1. Install O-rings (17, 18, 19) and rupture disc assembly (24, 25, 26) in power charge chamber (3).

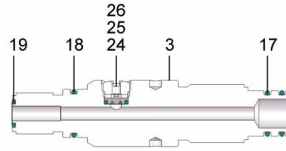

2. Screw upper cylinder (4) to power charge chamber.

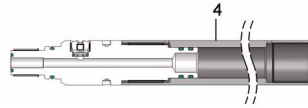

3. Install O-rings (17) on each end of tandem connector (5). Screw connector to upper cylinder.

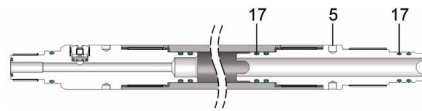

4. Screw middle cylinder (7) to tandem connector. Install O-rings (17) on upper piston (6). Install piston fully inside cylinder.

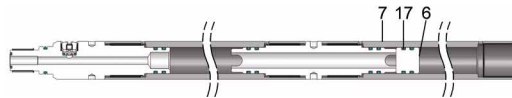

5. Fill cylinder with SAE 10-40 oil to following levels:
Well temp. Size 05
200°F or less 3-1/4 in.
200°F - 275°F 3-1/4 in.
275°F - 350°F 3-1/2 in.
350°F - 400°F 3-5/8 in.

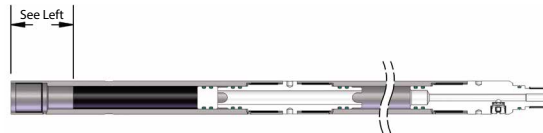

6. Install O-rings (17-18) on middle connector (8) then screw into middle cylinder with small orifice hole toward oil.



7. Install O-rings (18 & 20) to lower connector (11). Slide piston rod (14) inside lower connector. Install O-rings (18) on lower piston (9). Screw piston to piston rod.



8. Lubricate piston, lower connector threads and cylinder bore. Slide lower cylinder (10) over piston and make up to lower connector.

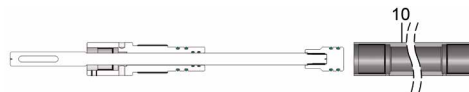

9. Screw setting mandrel (15) to lower connector hand tight. Install set screw (21).



10. Align slots in piston rod and setting mandrel. Slide retaining ring (12) over setting mandrel. Slide crosslink sleeve (16) over setting mandrel. Install crosslink (13) in slots. Slip retaining ring over crosslink and install set screws (22).

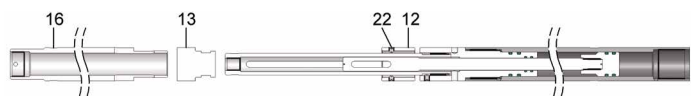

continued on next page

T-Set® Size 05

Assembly Instructions (continued)

11. Connect upper and lower halves of the tool together.

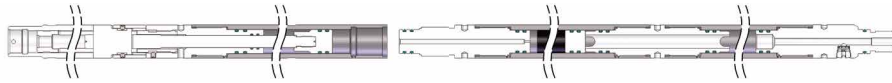

12. Place tool in vise and tighten all joints. Air trapped in cylinder during tightening should make crosslink sleeve stand off from cylinder head no more than 3/8 in.



T-Set® Size 05

Disassembly Instructions

Hose off setting assembly to clean and cool it.

1. Point the manual bleeder valve port away from you and turn the stem slowly to the left with the manual bleeder valve wrench until it shoulders on the nut, at which time the pressure should be bled off through the pressure vent. If the pressure will not bleed off, close the manual bleeder valve; otherwise, the valve should remain open during the entire disassembly procedure.
2. Unscrew the cable head. Important, if the cable head is tight, indicating pressure has leaked into it, proceed to step 3.
3. Remove the Adapter Kit from the pressure setting assembly.
4. Hold a back-up on lower cylinder. Position the bleed hole away from you. Slowly unscrew the lower connector until compressed air escapes through the bleeder hole. Do not back-off lower connector from lower cylinder more than 1-1/4 in.
5. Hold a back-up on the upper cylinder. Position the bleed hole away from you. Slowly unscrew the connector a distance of no more than 1-1/4 in. from the upper cylinder to allow any pressure that may still be trapped in cylinder to escape. Be sure to stand away from the bleed hole.
6. Caution: all pressurized gas must be bled off before further disassembly is begun. The two halves of the tool will blow apart.
7. Unscrew and remove firing head. Unscrew and remove pressure chamber and upper cylinder. Remove burnt power charge from upper cylinder.
8. Unscrew and remove connector and middle cylinder. Discard the oil. Push floating piston out lower end of middle cylinder. Remove O-rings from floating piston, connector, and pressure chamber.

Disassemble remainder of setting assembly components. Thoroughly remove power charge debris. Apply light coat of oil to all parts to prevent rust from forming.

O-ring care and replacement:

All O-rings must be replaced after each use. The O-rings should be lubricated with an appropriate lubricant. We recommend Hydrotex. Use only the O-rings specified in the setting tools parts lists. Use only O-rings or O-ring kits supplied and/or specifically engineered for T-Set® tools.

T-Set® Size 05

Minimum and Maximum Wear Diameters

The size 05 setting tool items shown below should be inspected periodically and any parts that have worn beyond the dimensions shown must be replaced.

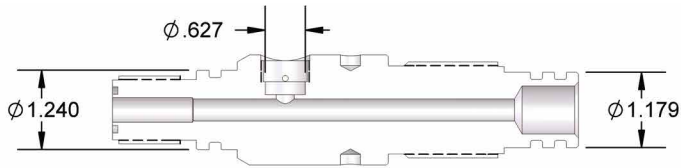

Power Charge Chamber
WST-BK05-020

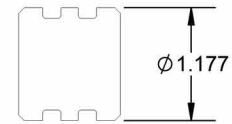

Upper Piston
WST-BK05-022

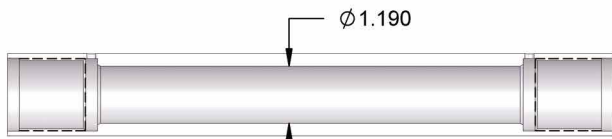

Upper and Middle Cylinder
WST-BK05-021 & WST-BK05-034

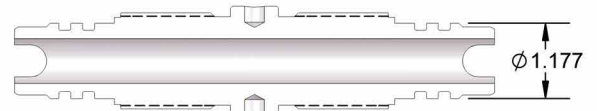

Tandem Connector
WST-BK05-023

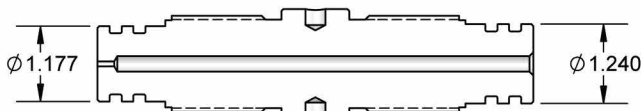

Middle Connector
WST-BK05-025

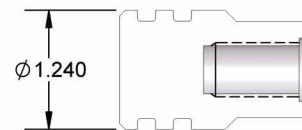

Lower Piston
WST-BK05-024

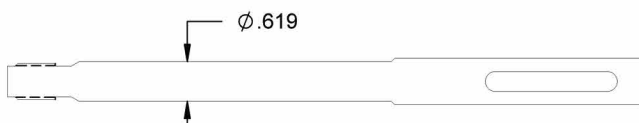

Piston Rod
WST-BK05-026

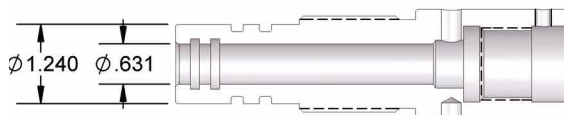

Lower Connector
WST-BK05-027

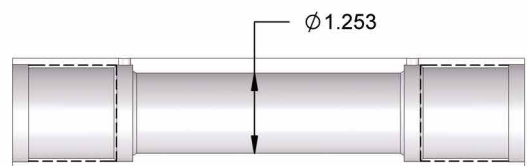

Lower Cylinder
WST-BK05-035

T-Set® Size 10 Setting Tool

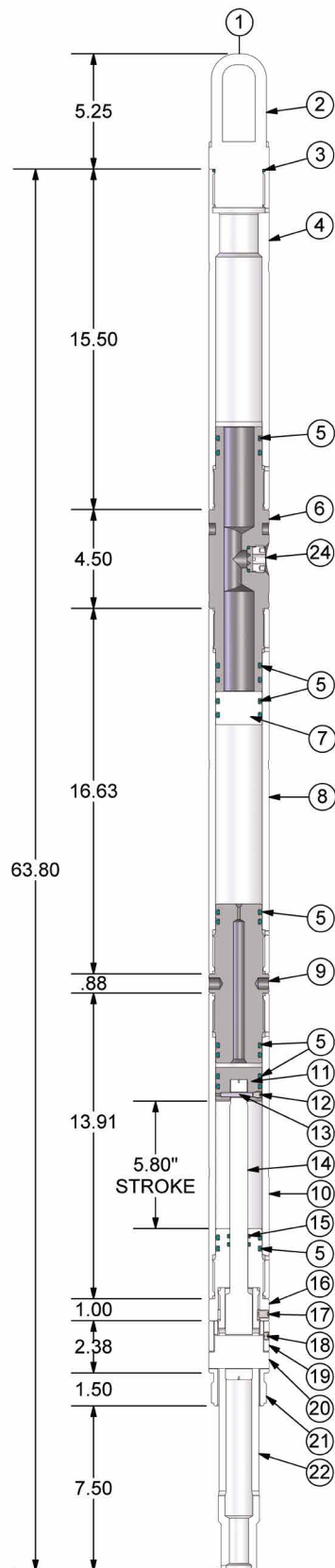

PARTS LIST

| ITEM | PART NUMBER | REQ. | DESCRIPTION |
|------|-----------------------|------|--|
| 1 | WST-BK10-001 | | Assy. - Size 10 - Incl. Items 2-26 |
| 2 | WST-BK10-PIN-PRO | 1 | Pin Protector |
| 3 | 0111-227-090 | 1 | O-ring - 90 Duro. |
| 4 | WST-BK10-020 | 1 | Power Charge Chamber |
| 5* | 0111-327-090 | 14 | O-ring - 90 Duro. |
| 6 | WST-BK10-034 | 1 | Ported Bleeder Sub |
| 7 | WST-BK10-022 | 1 | Upper Piston |
| 8 | WST-BK10-021 | 1 | Upper Cylinder |
| 9 | WST-BK10-023 | 1 | Tandem Connector |
| 10 | WST-BK10-035 | 1 | Lower Cylinder |
| 11 | WST-BK10-024 | 1 | Lower Piston |
| 12 | WST-SHCS-0025-20-0044 | 1 | Cup Point Set Screw - 1/4-20 x 3/8 lg. |
| 13 | WST-BK10-025 | 1 | Retaining Pin |
| 14 | WST-BK10-026 | 1 | Piston Rod |
| 15* | 0111-211-090 | 2 | O-ring - 90 Duro. |
| 16 | WST-BK10-027 | 1 | Cylinder Head |
| 17 | CPSS-0038-16-0050 | 1 | Cup Point Set Screw - 3/8 - 16 x 1/2 lg. |
| 18 | CPSS-0038-16-0025 | 1 | Cup Point Set Screw - 3/8 - 16 x 1/4 lg. |
| 19 | WST-BK10-029 | 1 | Retaining Ring |
| 20 | WST-BK10-031 | 1 | Crosslink |
| 21 | WST-BK10-028 | 1 | Crosslink Sleeve |
| 22 | WST-BK10-030 | 1 | Setting Mandrel |
| 23 | WST-3625-135 | 1 | Assy. - Disc Type Bleeder Valve - Incl. Items 24,25,26 |
| 24 | WST-3625-137 | 1 | Retainer Nut - for Disc Type Bleeder Valve |
| 25* | WST-3625-136 | 1 | Rupture Disc - for Disc Type Bleeder Valve |
| 26* | 0111-213-090 | 1 | O-ring - 90 Duro. - for Bleeder Valve |
| 27 | WST-3625-140 | | Rupture Wrench |
| * | WST-BK10-010 | | Redress Kit - for WST-BK10-001 Incl. Items 5,15,25,26 |
| | WST-3625-138 | | Rupture Disc Kit - Incl. Items 25 & 26 |

Note: high temp redress kits available upon request

| SIZE | MAX O.D. | MAX STROKE | MAX PULL STRENGTH |
|------|----------------------|-------------------|-------------------|
| 10 | 2.750 in. (6.985 cm) | 5.8 in. (14.7 cm) | 35,000 lb. |

Power Charges and Igniters referenced at the back of this catalog

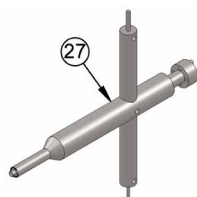

Rupture Wrench
WST-3625-140

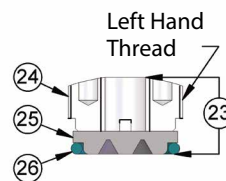

Rupture Disc Assy.
WST-3625-135

T-Set® Size 10 Assembly Instructions

1. Install O-rings and rupture disc assembly (5 & 23) in ported bleeder sub (6). Screw sub to pressure chamber (4).

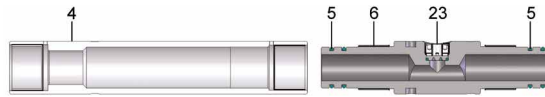

2. Screw upper cylinder (8) to ported bleeder sub (6). Install O-rings (5) on upper piston (7) then push piston through upper cylinder until it contacts ported bleeder sub.

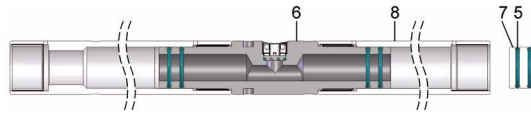

3. Fill cylinder with SAE 10-40 oil to following levels:
Well temp. Size 10
200°F or less 4 in.
200°F - 275°F 4-1/8 in.
275°F - 350°F 4-3/8 in.
350°F - 400°F 4-5/8 in.

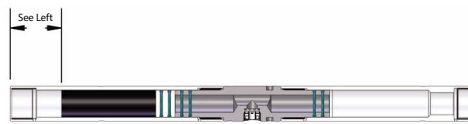

4. Install O-rings (5) on tandem connector (9) then screw into upper cylinder with small orifice hole toward oil.



5. Install O-rings (5 & 15) to cylinder head (16). Slide piston rod (14) inside cylinder head.

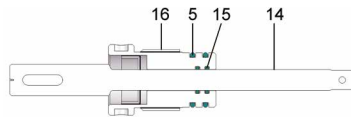

6. Screw setting mandrel (22) to cylinder head hand tight. Install set screw (17).

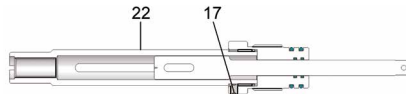

7. Align slots in piston rod and setting mandrel. Slide retaining ring (19) over setting mandrel. Slide crosslink sleeve (21) over setting mandrel. Install crosslink (20) in slots. Slip retaining ring over crosslink and install set screw (18).

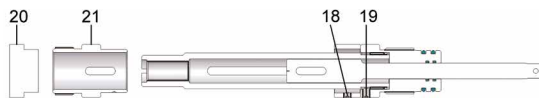

8. Install O-rings (5) to lower piston (11). Place piston rod. Install retaining pin (13) and set screw (12).

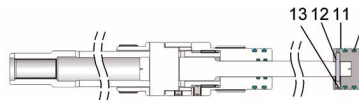

9. Lubricate piston, cylinder head threads, and cylinder bore. Slide lower cylinder (10) over piston and make up to cylinder head while making sure cylinder head is positioned against crosslink sleeve when cylinder is being made up.

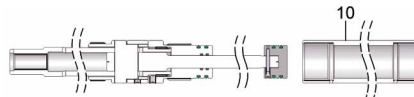

10. Connect upper and lower halves of the tool together.



11. Place tool in vise and tighten all joints. Air trapped in cylinder during tightening should make crosslink sleeve stand off from cylinder head no more than 3/8 in.



T-Set® Size 10 Non-Ported High Pressure Setting Tool

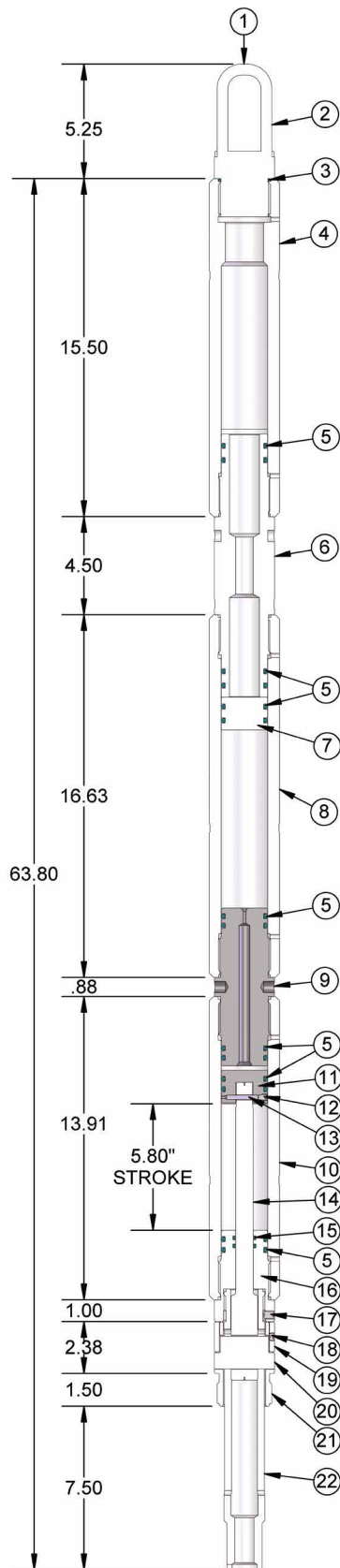

PARTS LIST

| ITEM | PART NUMBER | REQ. | DESCRIPTION |
|------|-----------------------|------|---|
| 1 | WST-BK10-002 | | Assy. - Size 10 High Pressure T-Set® - Incl. Items 2-22 |
| 2 | WST-BK10-PIN-PRO | 1 | Pin Protector |
| 3 | 0111-227-090 | 1 | O-ring - 90 Duro. |
| 4 | WST-BK10-050 | 1 | Power Charge Chamber - Size #10 High Pressure |
| 5* | 0111-327-090 | 14 | O-ring - 90 Duro. |
| 6 | WST-BK10-052 | 1 | Non Ported Bleeder Sub - High Pressure |
| 7 | WST-BK10-022 | 1 | Upper Piston |
| 8 | WST-BK10-051 | 1 | Upper Cylinder - High Pressure |
| 9 | WST-BK10-023 | 1 | Tandem Connector |
| 10 | WST-BK10-053 | 1 | Lower Cylinder - High Pressure |
| 11 | WST-BK10-024 | 1 | Lower Piston |
| 12 | WST-SHCS-0025-20-0044 | 1 | Cup Point Set Screw - 1/4-20 x 3/8 lg. |
| 13 | WST-BK10-025 | 1 | Retaining Pin |
| 14 | WST-BK10-026 | 1 | Piston Rod |
| 15* | 0111-211-090 | 2 | O-ring - 90 Duro. |
| 16 | WST-BK10-027 | 1 | Cylinder Head |
| 17 | CPSS-0038-16-0050 | 1 | Cup Point Set Screw - 3/8 - 16 x 1/2 lg. |
| 18 | CPSS-0038-16-0025 | 1 | Cup Point Set Screw - 3/8 - 16 x 1/4 lg. |
| 19 | WST-BK10-029 | 1 | Retaining Ring |
| 20 | WST-BK10-031 | 1 | Crosslink |
| 21 | WST-BK10-028 | 1 | Crosslink Sleeve |
| 22 | WST-BK10-030 | 1 | Setting Mandrel |
| * | WST-BK10-010-ND | | Redress Kit - for WST-BK10-002 & WST-B10-201 Incl. Items 5 & 15 |

| SIZE | MAX O.D. | MAX STROKE | MAX PULL STRENGTH |
|------|----------------------|-------------------|-------------------|
| 10 | 3.218 in. (8.173 cm) | 5.8 in. (14.7 cm) | 35,000 lb. |

Power Charges and Igniters referenced at the back of this catalog

T-Set® Size 10 Assembly Instructions

1. Install O-rings (5) in non-ported bleeder sub (6). Screw sub to pressure chamber (4).

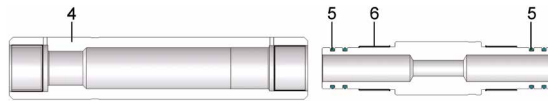

2. Screw upper cylinder (8) to non-ported bleeder sub (6). Install O-rings (5) on upper piston (7) then push piston through upper cylinder until it contacts non-ported bleeder sub.

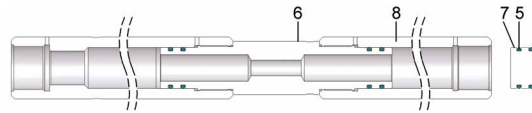

3. Fill cylinder with SAE 10-40 oil to following levels:
Well temp. Size 10
200°F or less 4 in.
200°F - 275°F 4-1/8 in.
275°F - 350°F 4-3/8 in.
350°F - 400°F 4-5/8 in.

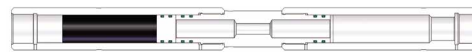

4. Install O-rings (5) on tandem connector (9) then screw into upper cylinder with small orifice hole toward oil.

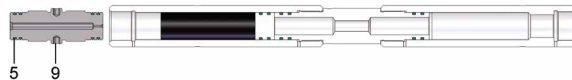

5. Install O-rings (5 & 15) to cylinder head (16). Slide piston rod (14) inside cylinder head.

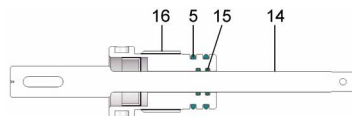

6. Screw setting mandrel (22) to cylinder head hand tight. Install set screw (17).

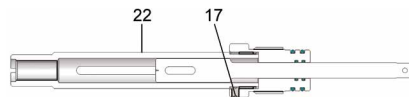

7. Align slots in piston rod and setting mandrel. Slide retaining ring (19) over setting mandrel. Slide crosslink sleeve (21) over setting mandrel. Install crosslink (20) in slots. Slip retaining ring over crosslink and install set screw (18).

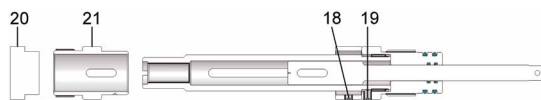

8. Install O-rings (5) to lower piston (11). Place piston rod. Install retaining pin (13) and set screw (12).

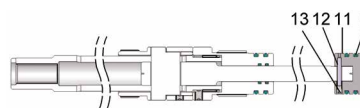

9. Lubricate piston, cylinder head threads, and cylinder bore. Slide lower cylinder (10) over piston and make up to cylinder head while making sure cylinder head is positioned against crosslink sleeve when cylinder is being made up.

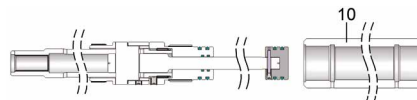

10. Connect upper and lower halves of the tool together.



11. Place tool in vise and tighten all joints. Air trapped in cylinder during tightening should make crosslink sleeve stand off from cylinder head no more than 3/8 in.



T-Set® Size 10 Non-Ported Setting Tool

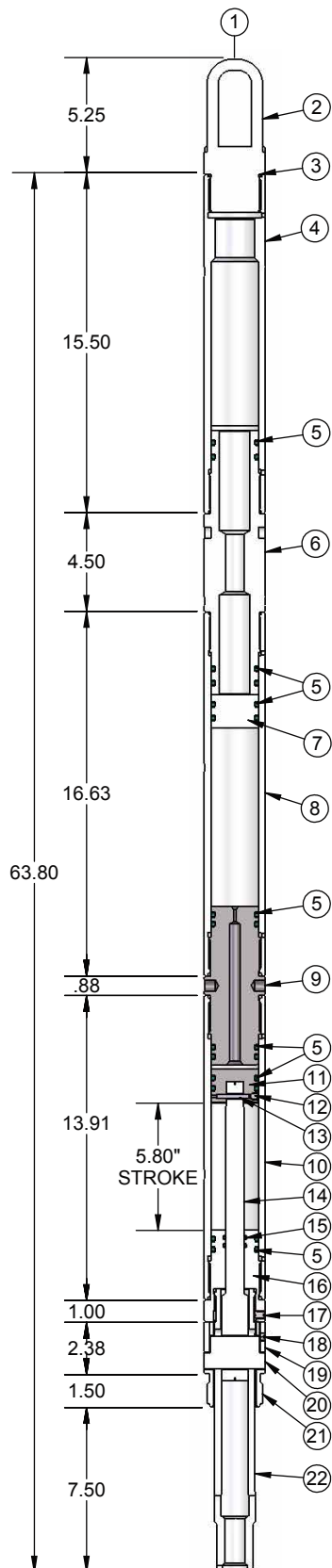

PARTS LIST

| ITEM | PART NUMBER | REQ. | DESCRIPTION |
|------|-----------------------|------|---|
| 1 | WST-BK10-201 | | Assy. - Size 10 Non Ported T-Set® - Incl. Items 2-22 |
| 2 | WST-BK10-PIN-PRO | 1 | Pin Protector |
| 3 | 0111-227-090 | 1 | O-ring - 90 Duro. |
| 4 | WST-BK10-020 | 1 | Power Charge Chamber |
| 5* | 0111-327-090 | 14 | O-ring - 90 Duro. |
| 6 | WST-BK10-052 | 1 | Non Ported Bleeder Sub - High Pressure |
| 7 | WST-BK10-022 | 1 | Upper Piston |
| 8 | WST-BK10-021 | 1 | Upper Cylinder |
| 9 | WST-BK10-023 | 1 | Tandem Connector |
| 10 | WST-BK10-035 | 1 | Lower Cylinder |
| 11 | WST-BK10-024 | 1 | Lower Piston |
| 12 | WST-SHCS-0025-20-0044 | 1 | Cup Point Set Screw - 1/4-20 x 3/8 lg. |
| 13 | WST-BK10-025 | 1 | Retaining Pin |
| 14 | WST-BK10-026 | 1 | Piston Rod |
| 15* | 0111-211-090 | 2 | O-ring - 90 Duro. |
| 16 | WST-BK10-027 | 1 | Cylinder Head |
| 17 | CPSS-0038-16-0050 | 1 | Cup Point Set Screw - 3/8 -16 x 1/2 lg. |
| 18 | CPSS-0038-16-0025 | 1 | Cup Point Set Screw - 3/8 -16 x 1/4 lg. |
| 19 | WST-BK10-029 | 1 | Retaining Ring |
| 20 | WST-BK10-031 | 1 | Crosslink |
| 21 | WST-BK10-028 | 1 | Crosslink Sleeve |
| 22 | WST-BK10-030 | 1 | Setting Mandrel |
| * | WST-BK10-010-ND | | Redress Kit - for WST-BK10-002 & WST-B10-201 Incl. Items 5 & 15 |

| SIZE | MAX O.D. | MAX STROKE | MAX PULL STRENGTH |
|------|----------------------|-------------------|-------------------|
| 10 | 3.218 in. (8.173 cm) | 5.8 in. (14.7 cm) | 35,000 lb. |

Power Charges and Igniters referenced at the back of this catalog

T-Set® Size 10 Non-Ported Assembly Instructions

1. Install O-rings (5) in non-ported bleeder sub (6). Screw sub to pressure chamber (4).

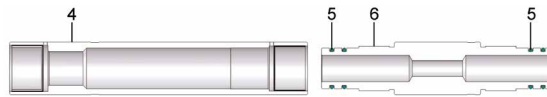

2. Screw upper cylinder (8) to non-ported bleeder sub (6). Install O-rings (5) on upper piston (7) then push piston through upper cylinder until it contacts non-ported bleeder sub.

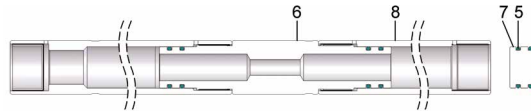

3. Fill cylinder with SAE 10-40 oil to following levels:
Well temp. Size 10
200°F or less 4 in.
200°F - 275°F 4-1/8 in.
275°F - 350°F 4-3/8 in.
350°F - 400°F 4-5/8 in.

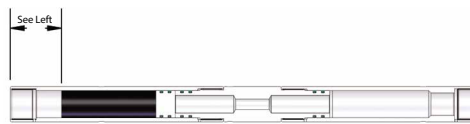

4. Install O-rings (5) on tandem connector (9) then screw into upper cylinder with small orifice hole toward oil.

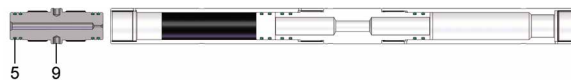

5. Install O-rings (5 & 15) to cylinder head (16). Slide piston rod (14) inside cylinder head.

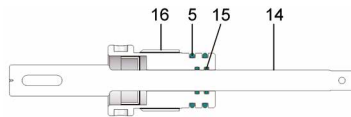

6. Screw setting mandrel (22) to cylinder head hand tight. Install set screw (17).

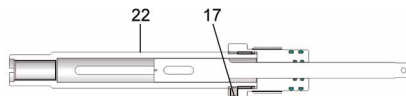

7. Align slots in piston rod and setting mandrel. Slide retaining ring (19) over setting mandrel. Slide crosslink sleeve (21) over setting mandrel. Install crosslink (20) in slots. Slip retaining ring over crosslink and install set screw (18).

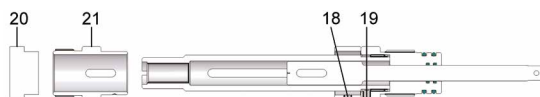

8. Install O-rings (5) to lower piston (11). Place piston rod. Install retaining pin (13) and set screw (12).

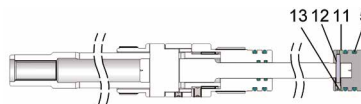

9. Lubricate piston, cylinder head threads, and cylinder bore. Slide lower cylinder (10) over piston and make up to cylinder head while making sure cylinder head is positioned against crosslink sleeve when cylinder is being made up.

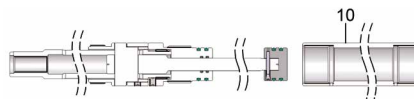

10. Connect upper and lower halves of the tool together.



11. Place tool in vise and tighten all joints. Air trapped in cylinder during tightening should make crosslink sleeve stand off from cylinder head no more than 3/8 in.



T-Set® Size 20 Setting Tool

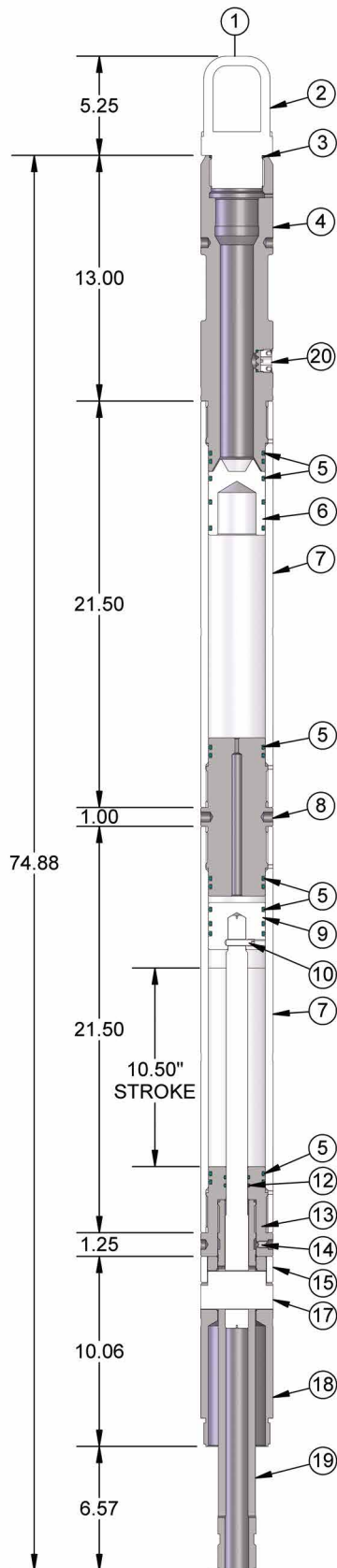

PARTS LIST

| ITEM | PART NUMBER | REQ. | DESCRIPTION |
|------|-------------------|------|--|
| 1 | WST-BK20-001 | | Assy. - Size 20 T-Set® - Incl. Items 2-23 |
| 2 | WST-BK20-PIN-PRO | 1 | Pin Protector |
| 3 | 0111-231-090 | 1 | O-ring - 90 Duro. |
| 4 | WST-BK20-020 | 1 | Power Charge Chamber |
| 5* | 0111-334-090 | 14 | O-ring - 90 Duro. |
| 6 | WST-BK20-022 | 1 | Upper Piston |
| 7 | WST-BK20-021 | 2 | Cylinder |
| 8 | WST-BK20-023 | 1 | Tandem Connector |
| 9 | WST-BK20-024 | 1 | Lower Piston |
| 10 | WST-BK20-025 | 1 | Lock Pin |
| 11 | WST-BK20-026 | 1 | Piston Rod |
| 12* | 0111-216-090 | 2 | O-ring - 90 Duro. |
| 13 | WST-BK20-027 | 1 | Cylinder Head |
| 14 | CPSS-0038-16-0050 | 1 | Cup Point Set Screw - 3/8-16 x 1/2 lg. |
| 15 | WST-BK20-029 | 1 | Crosslink Retaining Ring |
| 16 | SHCS-0025-20-0038 | 1 | Socket Head Cap Screw - 1/4-20 x 3/8 lg. |
| 17 | WST-BK20-031 | 1 | Crosslink |
| 18 | WST-BK20-028 | 1 | Crosslink Sleeve |
| 19 | WST-BK20-030 | 1 | Setting Mandrel |
| 20 | WST-3625-135 | 1 | Assy. - Disc Type Bleeder Valve - Incl. Items 21,22,23 |
| 21 | WST-3625-137 | 1 | Retainer Nut - for Disc Type Bleeder Valve |
| 22 | WST-3625-136 | 1 | Rupture Disc - for Disc Type Bleeder Valve |
| 23* | 0111-213-090 | 1 | O-ring - 90 Duro. |
| 24 | WST-3625-140 | | Rupture Wrench |
| * | WST-BK20-010 | | Redress Kit - for WST-BK20-001 Incl. Items 5,12, 22 & 23 |
| | WST-3625-138 | | Rupture Disc Kit - Incl. Items 22 And 23 |

Note: high temp redress kit available upon request

| SIZE | MAX O.D. | MAX STROKE | MAX PULL STRENGTH |
|------|----------------------|-------------------|-------------------|
| 20 | 3.812 in. (9.682 cm) | 11 in. (27.94 cm) | 55,000 lb. |

Power Charges and Igniters referenced at the back of this catalog

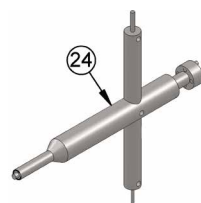

Rupture Wrench
WST-3625-140

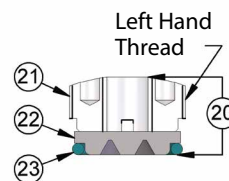

Rupture Disc Assy.
WST-3625-135

T-Set® Size 20 Assembly Instructions

1. Install O-rings and rupture disc assembly (5 & 20) in power charge chamber (4). Screw chamber to cylinder (7).

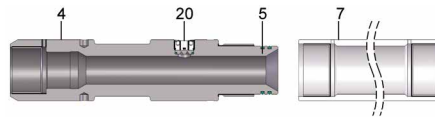

2. Install O-rings (5) on upper piston (7) then push piston through cylinder until it contacts power charge chamber.

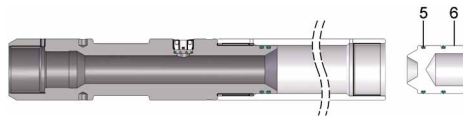

3. Fill cylinder with SAE 10-40 oil to following levels:

| Well temp. | Size 20 |
|---------------|-----------|
| 200°F or less | 4 in. |
| 200°F - 275°F | 4-1/2 in. |
| 275°F - 350°F | 5 in. |
| 350°F - 400°F | 5-1/2 in. |

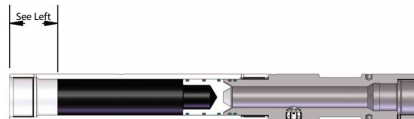

4. Install O-rings (5) on tandem connector (8) then screw into upper cylinder with small orifice hole toward oil.



5. Slide setting mandrel (19) inside crosslink sleeve (18). Long threaded end of mandrel positioned as shown.

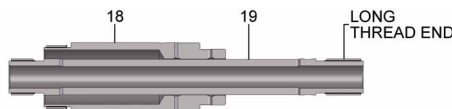

6. Slide piston rod (11) into setting mandrel (19).

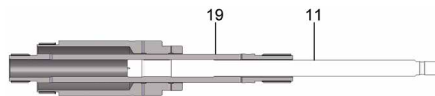

7. Align slots in all items and insert crosslink (17). Install retaining ring (15) and cap screw (16).

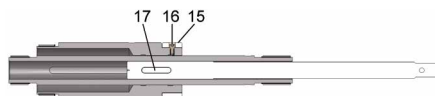

8. Install O-rings (5 & 12) to cylinder head (13). Slide head on piston rod. Make up head hand tight to setting mandrel. Install set screw (14).

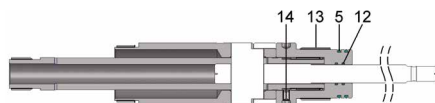

9. Install O-rings (5) on lower piston (9). Place piston on piston rod. Install lock pin (10) and tighten.



10. Lubricate piston, cylinder head threads, and cylinder bore. Slide cylinder (7) over piston and make up to cylinder head while making sure cylinder head is positioned against crosslink sleeve while cylinder is being made up.

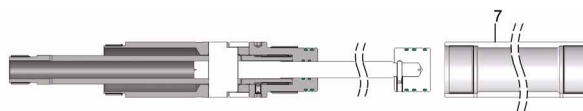

11. Connect upper and lower halves of the tool together.

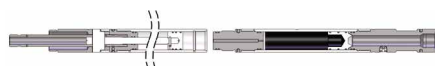

12. Place tool in vise and tighten all joints. Air trapped in cylinder during tightening should make crosslink sleeve stand off from cylinder head no more than 3/8 in.



T-Set® Size 20 Non-Ported

High Pressure Setting Tool

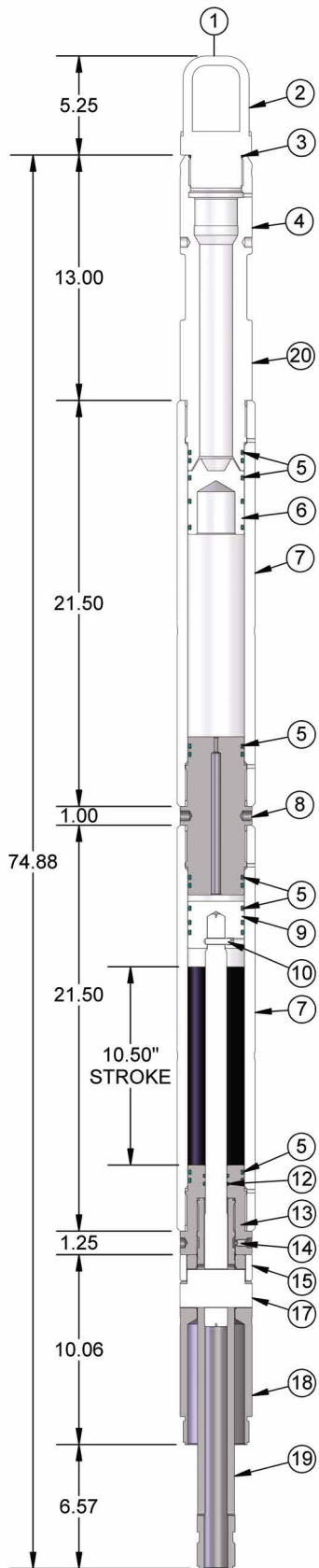

PARTS LIST

| ITEM | PART NUMBER | REQ. | DESCRIPTION |
|------|-------------------|------|--|
| 1 | WST-BK20-002 | | Assy. - Size 20 High Pressure T-Set® - Incl. Items 2-19 |
| 2 | WST-BK20-PIN-PRO | 1 | Pin Protector |
| 3 | 0111-231-090 | 1 | O-ring - 90 Duro. |
| 4 | WST-BK20-040 | 1 | Power Charge Chamber - High Press. - Unported |
| 5* | 0111-334-090 | 14 | O-ring - 90 Duro. |
| 6 | WST-BK20-022 | 1 | Upper Piston |
| 7 | WST-BK20-041 | 2 | Upper & Lower Cylinder - High Pressure |
| 8 | WST-BK20-023 | 1 | Tandem Connector |
| 9 | WST-BK20-024 | 1 | Lower Piston |
| 10 | WST-BK20-025 | 1 | Lock Pin |
| 11 | WST-BK20-026 | 1 | Piston Rod |
| 12* | 0111-216-090 | 2 | O-ring - 90 Duro. |
| 13 | WST-BK20-027 | 1 | Cylinder Head |
| 14 | CPSS-0038-16-0050 | 1 | Cup Point Set Screw - 3/8-16 x 1/2 lg. |
| 15 | WST-BK20-029 | 1 | Crosslink Retaining Ring |
| 16 | SHCS-0025-20-0038 | 1 | Socket Head Cap Screw - 1/4-20 x 3/8 lg. |
| 17 | WST-BK20-031 | 1 | Crosslink |
| 18 | WST-BK20-028 | 1 | Crosslink Sleeve |
| 19 | WST-BK20-030 | 1 | Setting Mandrel |
| * | WST-BK20-010ND | | Redress Kit - for WST-BK20-002 & WST-BK20-201 Incl. Items 5 & 12 |

Note: high temp redress kit available upon request

| SIZE | MAX O.D. | MAX STROKE | MAX PULL STRENGTH |
|------|----------------------|-------------------|-------------------|
| 20 | 3.812 in. (9.682 cm) | 11 in. (27.94 cm) | 55,000 lb. |

Power Charges and Igniters referenced at the back of this catalog

T-Set® Size 20 Assembly Instructions

1. Install O-rings (5) in power charge chamber (4). Screw chamber to cylinder (7).

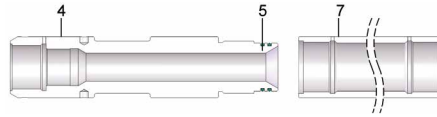

2. Install O-rings (5) on upper piston (6) then push piston through cylinder until it contacts power charge chamber.

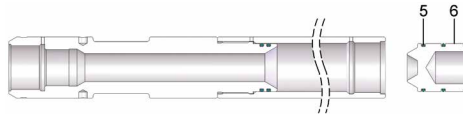

3. Fill cylinder with SAE 10-40 oil to following levels:
Well temp. Size 20
200°F or less 4 in.
200°F - 275°F 4-1/2 in.
275°F - 350°F 5 in.
350°F - 400°F 5-1/2 in.

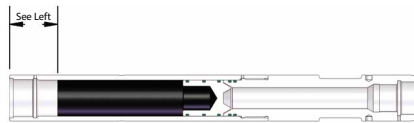

4. Install O-rings (5) on tandem connector (8) then screw into upper cylinder with small orifice hole toward oil.



5. Slide setting mandrel (19) inside crosslink sleeve (18). Long threaded end of mandrel positioned as shown.

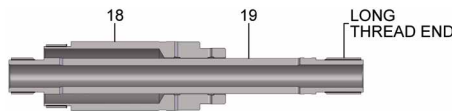

6. Slide piston rod (11) into setting mandrel (19).

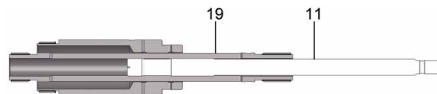

7. Align slots in all items and insert crosslink (17). Install retaining ring (15) and cap screw (16).

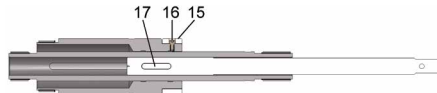

8. Install O-rings (5 & 12) to cylinder head (13). Slide head on piston rod. Make up head hand tight to setting mandrel. Install set screw (14).

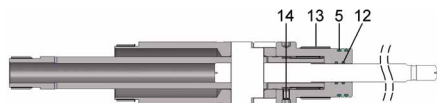

9. Install O-rings (5) on lower piston (9). Place piston on piston rod. Install lock pin (10) and tighten.



10. Lubricate piston, cylinder head threads, and cylinder bore. Slide cylinder (7) over piston and make up to cylinder head while making sure cylinder head is positioned against crosslink sleeve while cylinder is being made up.

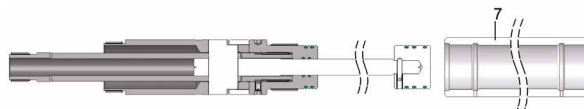

11. Connect upper and lower halves of the tool together.

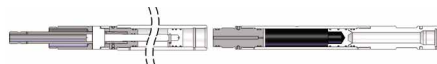

12. Place tool in vise and tighten all joints. Air trapped in cylinder during tightening should make crosslink sleeve stand off from cylinder head no more than 3/8 in.



T-Set® Size 20 Non-Ported Setting Tool

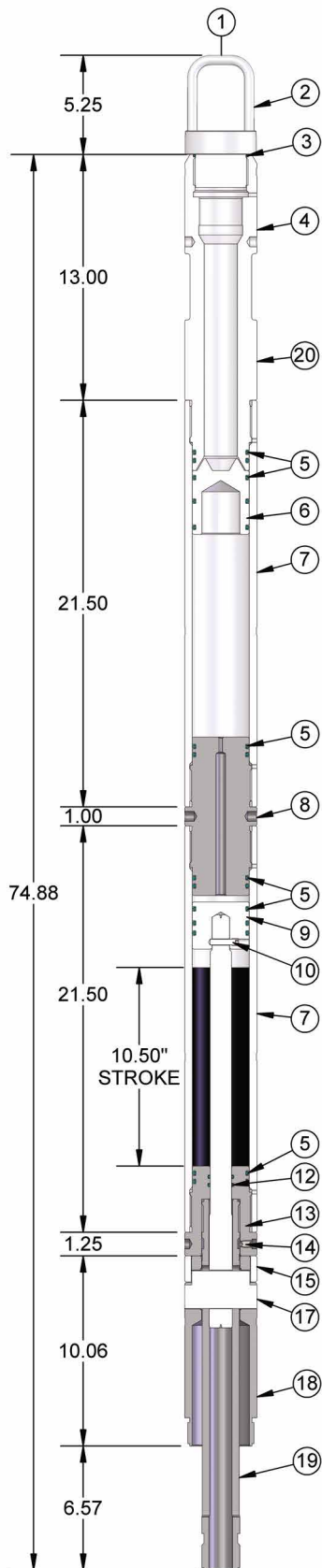

PARTS LIST

| ITEM | PART NUMBER | REQ. | DESCRIPTION |
|------|-------------------|------|---|
| 1 | WST-BK20-201 | | Assy. - Size 20 Non Ported T-Set® - Incl. Items 2-19 |
| 2 | WST-BK20-PIN-PRO | 1 | Pin Protector |
| 3 | 0111-231-090 | 1 | O-ring - 90 Duro. |
| 4 | WST-BK20-040 | 1 | Power Charge Chamber - High Press. - Unported |
| 5* | 0111-334-090 | 14 | O-ring - 90 Duro. |
| 6 | WST-BK20-022 | 1 | Upper Piston |
| 7 | WST-BK20-021 | 2 | Upper & Lower Cylinder |
| 8 | WST-BK20-023 | 1 | Tandem Connector |
| 9 | WST-BK20-024 | 1 | Lower Piston |
| 10 | WST-BK20-025 | 1 | Lock Pin |
| 11 | WST-BK20-026 | 1 | Piston Rod |
| 12* | 0111-216-090 | 2 | O-ring - 90 Duro. |
| 13 | WST-BK20-027 | 1 | Cylinder Head |
| 14 | CPSS-0038-16-0050 | 1 | Cup Point Set Screw - 3/8-16 x 1/2 lg. |
| 15 | WST-BK20-029 | 1 | Crosslink Retaining Ring |
| 16 | SHCS-0025-20-0038 | 1 | Socket Head Cap Screw - 1/4-20 x 3/8 lg. |
| 17 | WST-BK20-031 | 1 | Crosslink |
| 18 | WST-BK20-028 | 1 | Crosslink Sleeve |
| 19 | WST-BK20-030 | 1 | Setting Mandrel |
| * | WST-BK20-010ND | | Redress Kit - for WST-BK20-002 & 201 Incl. Items 5 & 12 |

Note: high temp redress kit available upon request

| SIZE | MAX O.D. | MAX STROKE | MAX PULL STRENGTH |
|------|----------------------|-------------------|-------------------|
| 20 | 3.812 in. (9.682 cm) | 11 in. (27.94 cm) | 55,000 lb. |

Power Charges and Igniters referenced at the back of this catalog

T-Set® Size 20 Assembly Instructions

1. Install O-rings (5) in power charge chamber (4). Screw chamber to cylinder (7).

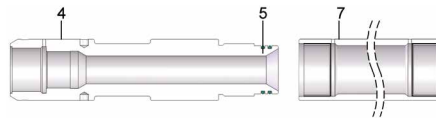

2. Install O-rings (5) on upper piston (6) then push piston through cylinder until it contacts power charge chamber.

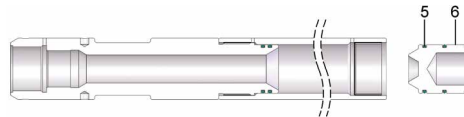

3. Fill cylinder with SAE 10-40 oil to following levels:

| Well temp. | Size 20 |
|---------------|-----------|
| 200°F or less | 4 in. |
| 200°F - 275°F | 4-1/2 in. |
| 275°F - 350°F | 5 in. |
| 350°F - 400°F | 5-1/2 in. |

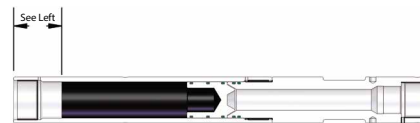

4. Install O-rings (5) on tandem connector (8) then screw into upper cylinder with small orifice toward oil.



5. Slide setting mandrel (19) inside crosslink sleeve (18). Long threaded end of mandrel positioned as shown.

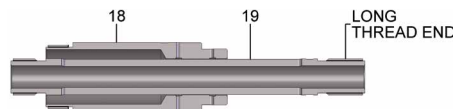

6. Slide piston rod (11) into setting mandrel (19).

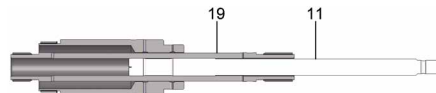

7. Align slots in all items and insert crosslink (17). Install retaining ring (15) and cap screw (16).

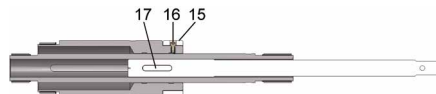

8. Install O-rings (5 & 12) to cylinder head (13). Slide head on piston rod. Make up head hand tight to setting mandrel. Install set screw (14).

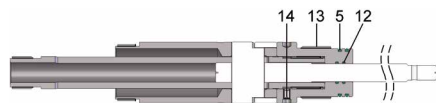

9. Install O-rings (5) on lower piston (9). Place piston on piston rod. Install lock pin (10) and tighten.

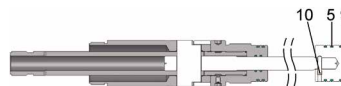

10. Lubricate piston, cylinder head threads, and cylinder bore. Slide cylinder (7) over piston and make up to cylinder head while making sure cylinder head is positioned against crosslink sleeve while cylinder is being made up.

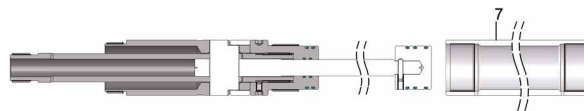

11. Connect upper and lower halves of the tool together.

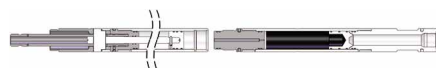

12. Place tool in vise and tighten all joints. Air trapped in cylinder during tightening should make crosslink sleeve stand off from cylinder head no more than 3/8 in.



T-Set® Size 10 and 20 Disassembly Instructions

Hose off setting assembly to clean and cool it. Unscrew the cable head. If the cable head is tight, pressure may have leaked into it. In this case bleed pressure from tool (steps 3 and 4) before removing cable head.

1. Remove the setting adapter kit. Hold ear of lock spring with pliers and twist against spring to relieve the bind on the threads. Unscrew the tension mandrel.
2. Place chain tongs around lower cylinder. Position bleeder holes in cylinder facing away from you and slowly unscrew cylinder head until compressed air escapes. Do not back-off cylinder head from cylinder more than 1-1/4 in.
3. Preferred gas pressure bleed-off method: position setting assembly so that side vent for manual bleeder valve is facing away from you and the bleeder stem is facing up. Using bleeder wrench, slowly turn stem to left until gas pressure escapes through the side vent. The stem will shoulder at retainer nut.
4. Alternate gas pressure bleed-off method: place chain tongs around pressure chamber. Position bleeder hole in pressure chamber facing away from you. Slowly unscrew the firing head until gas pressure bleeds off. Do not back-off firing head from pressure chamber more than 1-1/4 in.
5. Alternate gas pressure bleed-off method: should pressure not bleed off as explained in steps 4 and 5 another method is available. Place chain tongs around upper cylinder and position bleeder hole in cylinder pointing away from you. Slowly unscrew the pressure chamber until gas pressure bleeds off. Do not back-off pressure chamber from upper cylinder more than 1-1/4 in.
6. If gas pressure still does not bleed off, back off firing head exactly 1-1/4 in. From pressure chamber. Positively stand clear of bleeder hole during this procedure.
7. Caution: all pressurized gas must be bled off before further disassembly is begun. The two halves of the tool will blow apart.
8. Unscrew and remove firing head. Unscrew and remove pressure chamber and upper cylinder.
9. Push upper piston out lower end of upper cylinder. Remove O-rings from pressure chamber, upper piston, and firing head.

Disassemble remainder of setting assembly components. Thoroughly remove power charge debris. Apply light coat of oil to all parts to prevent rust from forming.

O-ring care and replacement:

All O-rings must be replaced after each use. The O-rings should be lubricated with an appropriate lubricant. We recommend Hydrotex. Use only the O-rings specified in the setting tools parts lists. Use only O-rings or O-ring kits supplied and/or specifically engineered for T-Set® tools.

T-Set® Size 10-20

Minimum and Maximum Wear Diameters

Size 10 and 20 setting tools items shown below should be inspected periodically and any parts that have worn beyond the dimensions shown must be replaced.

| | SIZE 10 | SIZE 20 |
|---|-----------------------|-----------------------|
| A | 2.130 in. (5.410 cm.) | 3.004 in. (7.630 cm.) |
| B | 1.755 in. (4.458 cm.) | 2.255 in. (5.728 cm.) |
| C | 2.115 in. (5.372 cm.) | 2.990 in. (7.595 cm.) |
| D | .809 in. (2.055 cm.) | 1.122 in. (2.850 cm.) |
| E | 2.115 in. (5.372 cm.) | 2.990 in. (7.595 cm.) |
| F | 2.115 in. (5.372 cm.) | 2.990 in. (7.595 cm.) |
| G | .820 in. (2.083 cm.) | 1.132 in. (2.875 cm.) |

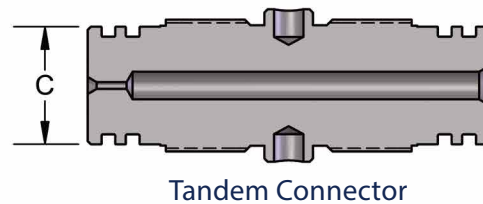
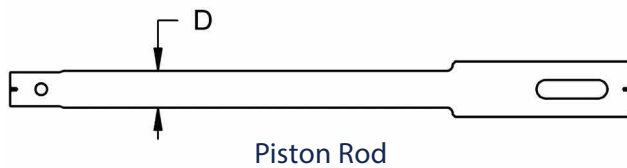
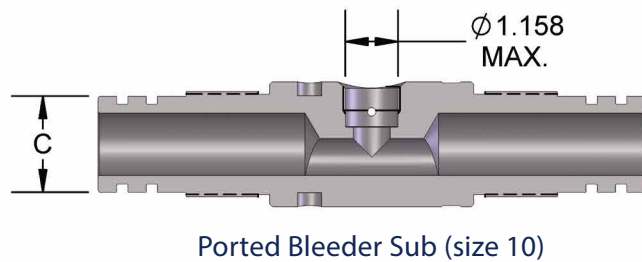
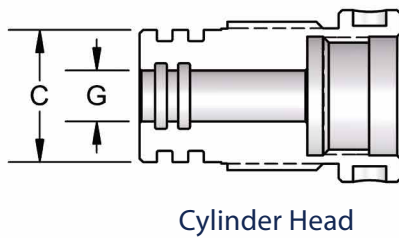
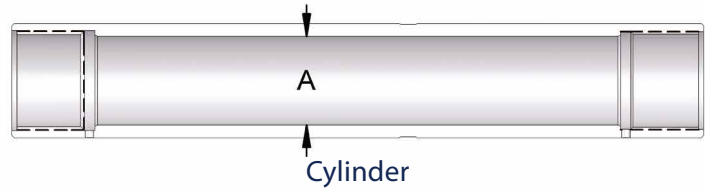
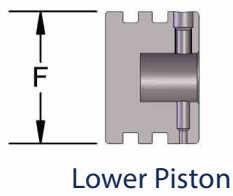
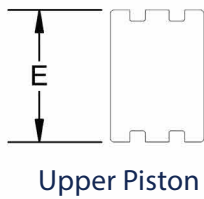
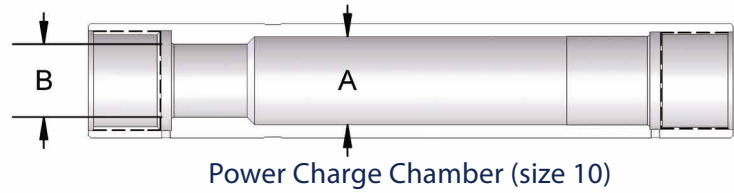
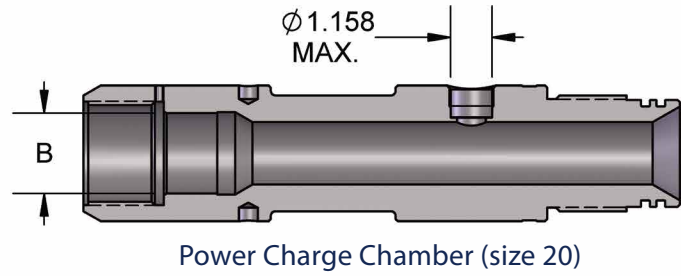

Firing Head Assembly

For Size 05 T-Set® Setting Tool

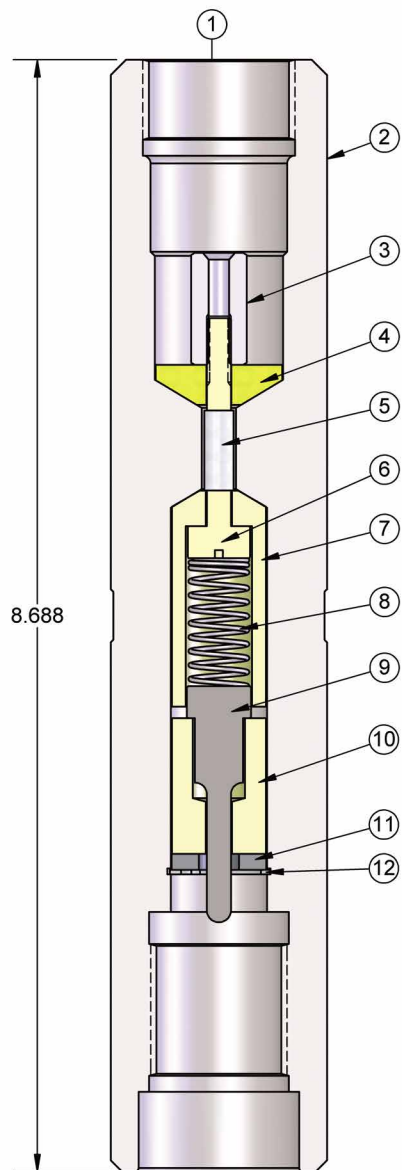

PARTS LIST

| ITEM | PART NUMBER | REQ. | DESCRIPTION |
|------|-------------------|------|--|
| 1 | 2005-000-000 | | Assy. - Firing Head for Size 05 T-Set® Setting Tool - Incl. Items 2-12 |
| 2 | 2005-000-001 | 1 | Firing Head Body |
| 3 | 0255-000-004 | 1 | Contact Socket |
| 4 | 0255-000-003 | 1 | Insulating Washer |
| 5 | 1002-000-4TI-.625 | 1 | Teflon Insulated Tube |
| 6 | 2005-000-005 | 1 | Contact Rod |
| 7 | 2005-000-003 | 1 | Spring Insulator |
| 8 | 2005-000-008 | 1 | Contact Spring |
| 9 | 2005-000-009 | 1 | Contact Plunger |
| 10 | 2005-000-006 | 1 | Plunger Insulator |
| 11 | 2005-000-004 | 1 | Retaining Washer |
| 12 | 0256-000-009 | 1 | Snap Ring |

Power Charges and Igniters referenced at the back of this catalog

2005-000-000

Assembly Instructions

1. Place the contact rod (6) into the spring insulator (7). Then install the teflon insulated tube (5) onto the contact rod.

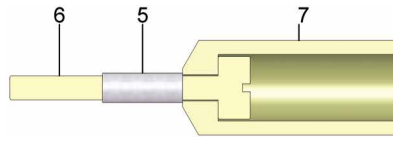

2. Place spring insulator (7) and contact rod (6) into lower end of the firing head body (2).

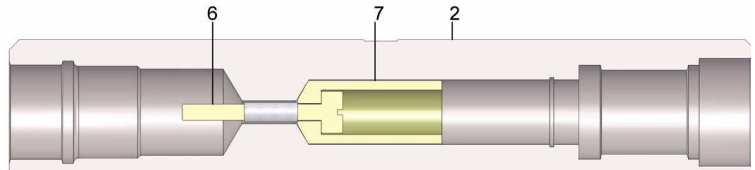

3. Place the insulating washer (4) into the upper end of the firing head body (2). Place insulating washer onto contact rod (6). Install with the tapered side facing into the firing head body.

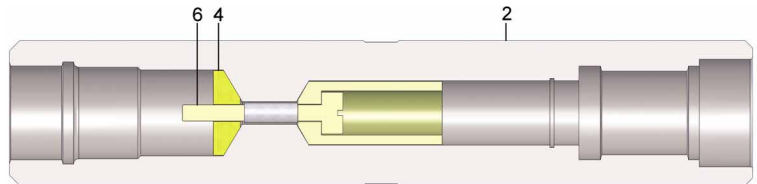

4. Tighten the contact socket (3) onto the contact rod (6) with a screwdriver and a deep 3/8 in. socket or nutdriver.

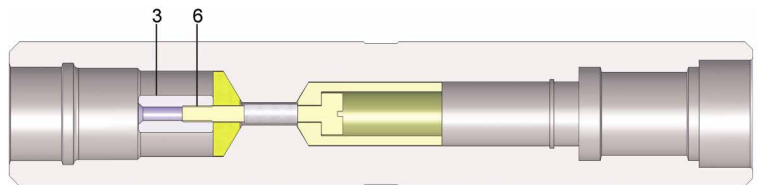

5. Install the contact spring (8) into the spring insulator (7). Then place the plunger insulator (10) onto the contact plunger (9) with the small diameter up.

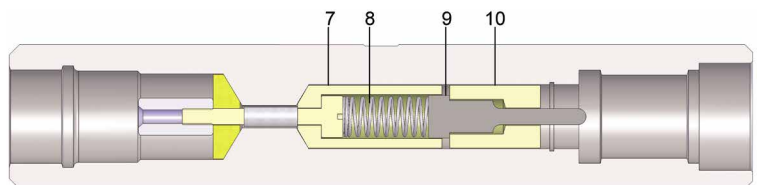

6. Place retaining washer (11) into firing head body. Then install the snap ring (12) to retain the washer.

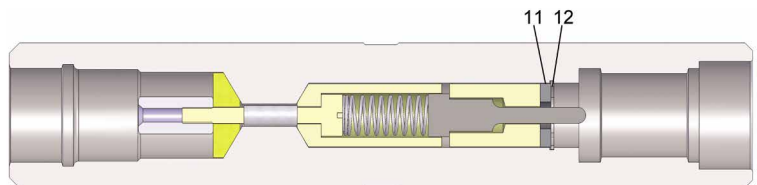

Firing Head Assembly

For Size 10 T-Set® Setting Tool

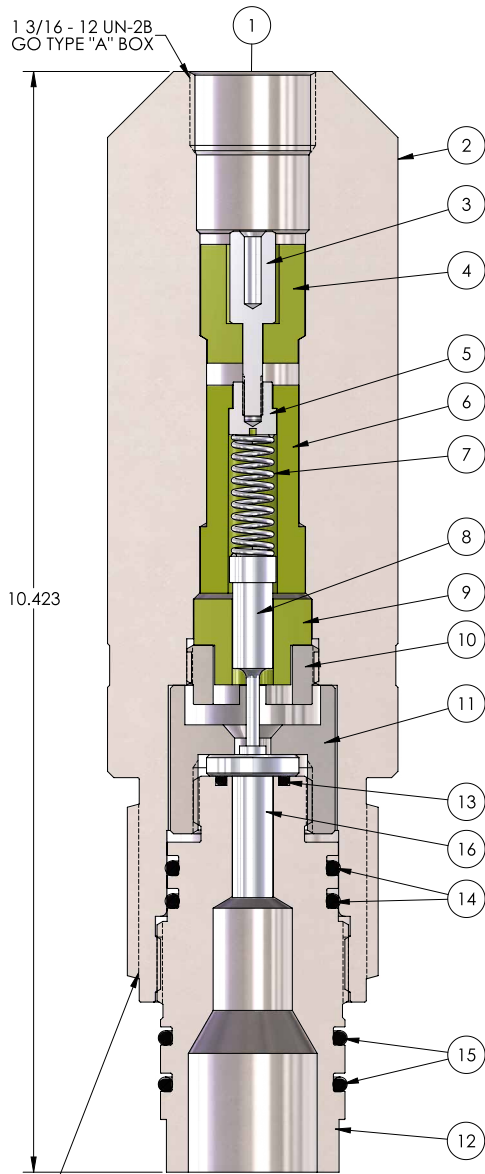

PARTS LIST

| ITEM | PART NUMBER | REQ. | DESCRIPTION |
|------|-----------------|------|--|
| 1 | 2010-000-000 | | Assy. - Firing Head for Size 10 T-Set® Setting Tool - Incl. Items 2-15 |
| 2 | 2010-000-001 | 1 | Firing Head Body |
| 3 | 2020-000-003 | 1 | Contact Socket |
| 4 | 2020-000-004 | 1 | Socket Insulator |
| 5 | 2020-000-006 | 1 | Contact Nut |
| 6 | 2020-000-005 | 1 | Contact Insulator |
| 7 | 2020-000-007 | 1 | Contact Spring |
| 8 | 2020-000-008 | 1 | Contact Pin |
| 9 | 2010-000-005 | 1 | Pin Insulator |
| 10 | 2010-000-004 | 1 | Retainer Nut |
| 11 | 2010-000-015 | 1 | Igniter Holder Cap |
| 12 | 0111-112-V95 | 1 | O-ring - Viton-95 |
| 13 | 0111-220-V95 | 2 | O-ring - Viton-95 |
| 14 | 2010-000-014 | 1 | Igniter Holder |
| 15 | 0111-222-V95 | 2 | O-ring - Viton-95 |
| 16 | DB-DET-2700-075 | 1 | BP-3 Igniter |

Power Charges and Igniters referenced at the back of this catalog

2010-000-000

Assembly Instructions

1. Place this contact socket (3) into the socket insulator (4).

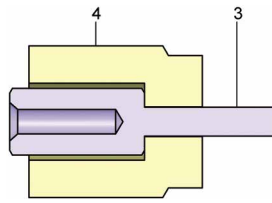

2. Place contact socket (3) and socket insulator (4) into upper end of the firing head body (2).

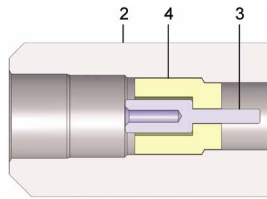

3. Place the contact nut (5) into the contact insulator (6).

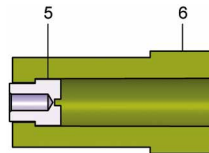

4. Install the contact insulator (6) and contact nut (5) into firing head (2). Tighten the contact nut (5) onto the contact socket (3) with a screwdriver and a deep 5/16 socket or nutdriver.

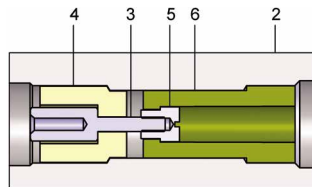

5. Install the contact spring (7) into the contact insulator (6). Then place the pin insulator (9) onto the contact pin (8) with the small diameter up.
6. Lightly grease the thread on the retainer nut (10). Place the retainer nut (10) onto the pin insulator (9) with the contact pin (8) inside. Then install and tighten with a retaining wrench (2010-000-016) while depressing the contact spring (7).

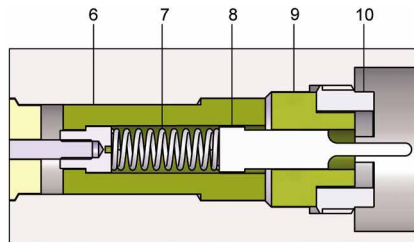

7. Install the 0111-220-V95 O-rings (13) and the 0111-112-V95 O-rings (12) onto the igniter holder (14). (Lightly grease the 0111-220-V95 O-rings and thread.)
8. Install the igniter (15) into the igniter holder (14) and thread the igniter holder cap (11) over it.
9. Install the igniter holder (14) with the igniter (16) installed into the firing head body (2). Note: left hand threads.

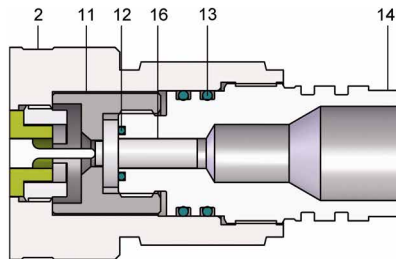

10. Install the 0111-222-V95 O-rings (15). (Use grease on the 0111-222-V95 O-rings.)

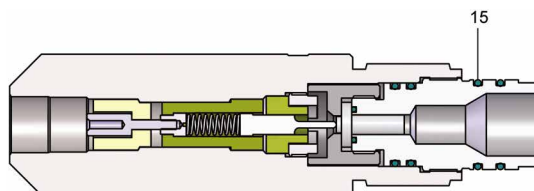

Firing Head Assembly

For Size 10 T-Set® Setting Tool

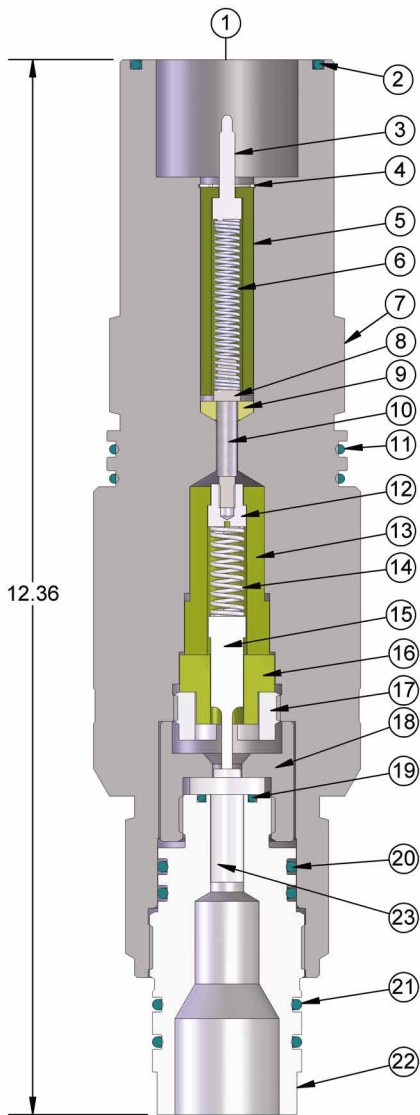

PARTS LIST

| ITEM | PART NUMBER | REQ. | DESCRIPTION |
|------|-----------------|------|--|
| 1 | 2010-000-020 | | Assy. - Firing Head for Size 10 T-Set® Setting Tool - Incl. Items 2-22 |
| 2 | 0111-226-V95 | 1 | O-ring - Viton-95 |
| 3 | 3903-000-010 | 1 | Contact Plunger |
| 4 | 3903-000-012 | 1 | Snap Ring |
| 5 | 3903-000-011 | 1 | Plunger Insulator |
| 6 | 3903-000-009 | 1 | Contact Spring |
| 7 | 2010-000-021 | 1 | Firing Head Body |
| 8 | 2010-000-311 | 1 | Contact Rod |
| 9 | 3903-000-007 | 1 | Insulating Washer |
| 10 | 2010-000-312 | 1 | Teflon Insulated Tube |
| 11 | 0111-230-V95 | 2 | O-ring - Viton-95 |
| 12 | 2020-000-006 | 1 | Contact Sub |
| 13 | 2020-000-005 | 1 | Contact Insulator |
| 14 | 2020-000-007 | 1 | Contact Spring |
| 15 | 2020-000-008 | 1 | Contact Pin |
| 16 | 2010-000-005 | 1 | Pin Insulator |
| 17 | 2010-000-004 | 1 | Retainer Nut |
| 18 | 2010-000-015 | 1 | Igniter Holder Cap |
| 19 | 0111-112-V95 | 1 | O-ring - Viton-95 |
| 20 | 0111-220-V95 | 2 | O-ring - Viton-95 |
| 21 | 0111-222-V95 | 2 | O-ring - Viton-95 |
| 22 | 2010-000-014 | 1 | Igniter Holder |
| 23 | DB-DET-2700-075 | 1 | BP-3 Igniter |

Power Charges and Igniters referenced at the back of this catalog

2010-000-020

Assembly Instructions

- Place the teflon insulated tube (10) onto the contact rod (8).

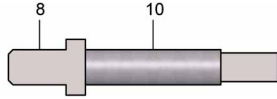

- Place the contact rod (8) and teflon insulated tube (10) into the insulating washer (9). Use care to ensure that the taper side faces away from the hex shaped portion of the contact rod.

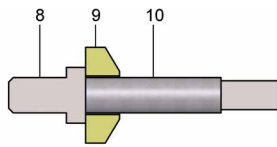

- Place insulating washer (9) and contact rod (8) with insulation (10) into upper end of the firing head body (7).

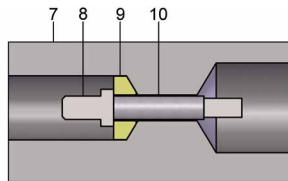

- Place contact nut (12) into the contact insulator (13).

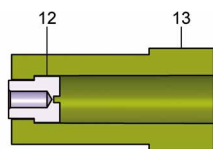

- Install the contact insulator (13) and contact nut (12) into firing head body (7). Tighten the contact nut (12) onto the contact rod (8) with a screwdriver and a deep 5/16 socket or nutdriver.

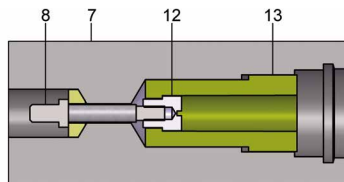

- Install contact spring (6) firmly onto the contact plunger (3) (this will require twisting).



- Place this contact plunger (3) and spring (6) assembly into firing head body (7). With the contact plunger (3) pointing up.

- Install the plunger insulator (5) over the plunger. Depress the spring (6) with the plunger insulator. Install the snap ring (4) to retain the plunger insulator.

- Using pliers, gently twist the contact plunger (3) counter clockwise to ensure spring contact.

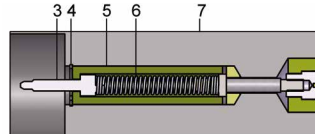

- Install the contact spring (14) into the contact insulator (13). Then place the pin insulator (16) onto the contact pin (15) with the small diameter up.

- Lightly grease the thread on the retainer nut (17). Place the retainer nut onto the pin insulator (16) with the contact pin (15) inside. Then install and tighten with a retaining ring wrench (2010-000-016) while depressing the contact spring (14).

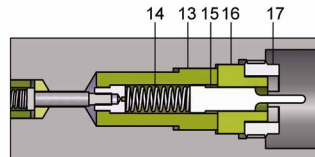

- Install the 0111-220-V95 O-rings (20) and the 0111-112-V95 O-rings (19) onto the igniter holder (22). (Lightly grease the 0111-220-V95 O-rings and threads.)

- Install the igniter (23) into the igniter holder (15) and thread the igniter holder cap (18) over it.

- Install the igniter holder (15). With the igniter (22) installed, into the firing head body (7). Note: left hand thread.

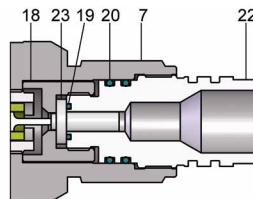

- Install the 0111-222-V95 (21), 0111-230-V95 (11) and 0111-226-V95 (2) O-rings. (Use grease on the 0111-222-V95 and 0111-230-V95 O-rings).

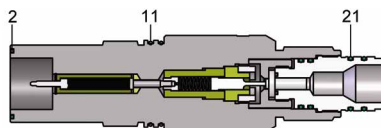

Firing Head Assembly

For Size 10 T-Set® Setting Tool

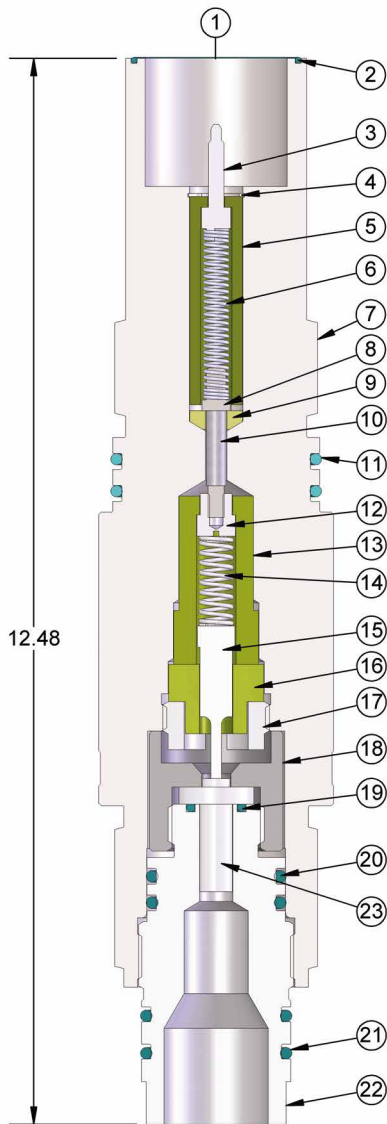

PARTS LIST

| ITEM | PART NUMBER | REQ. | DESCRIPTION |
|------|-----------------|------|--|
| 1 | 2010-000-040 | | Assy. - Firing Head for Size 10 T-Set® Setting Tool - Incl. Items 2-22 |
| 2 | 0111-032-V95 | 1 | O-ring - Viton-95 |
| 3 | 3903-000-010 | 1 | Contact Plunger |
| 4 | 3903-000-012 | 1 | Snap Ring |
| 5 | 3903-000-011 | 1 | Plunger Insulator |
| 6 | 3903-000-009 | 1 | Contact Spring |
| 7 | 2010-000-041 | 1 | Firing Head Body |
| 8 | 2010-000-311 | 1 | Contact Rod |
| 9 | 3903-000-007 | 1 | Insulating Washer |
| 10 | 2010-000-312 | 1 | Teflon Insulated Tube |
| 11 | 0111-227-V95 | 2 | O-ring - Viton-95 |
| 12 | 2020-000-006 | 1 | Contact Sub |
| 13 | 2020-000-005 | 1 | Contact Insulator |
| 14 | 2020-000-007 | 1 | Contact Spring |
| 15 | 2020-000-008 | 1 | Contact Pin |
| 16 | 2010-000-005 | 1 | Pin Insulator |
| 17 | 2010-000-004 | 1 | Retainer Nut |
| 18 | 2010-000-015 | 1 | Igniter Holder Cap |
| 19 | 0111-112-V95 | 1 | O-ring - Viton-95 |
| 20 | 0111-220-V95 | 2 | O-ring - Viton-95 |
| 21 | 0111-222-V95 | 2 | O-ring - Viton-95 |
| 22 | 2010-000-014 | 1 | Igniter Holder |
| 23 | DB-DET-2700-075 | 1 | BP-3 Igniter |

Power Charges and Igniters referenced at the back of this catalog

2010-000-040

Assembly Instructions

- Place the teflon insulated tube (10) onto the contact rod (8).

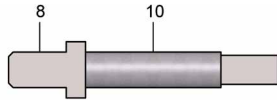

- Place the contact rod (8) and teflon insulated tube (10) into the insulating washer (9). Use care to ensure that the taper side faces away from the hex shaped portion of the contact rod.

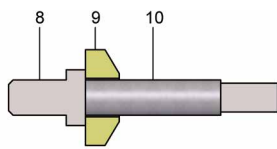

- Place insulating washer (9) and contact rod (8) with insulation (10) into upper end of the firing head body (7).

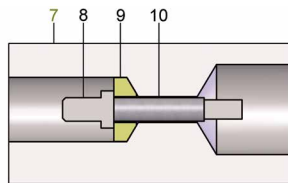

- Place contact nut (12) into the contact insulator (13).

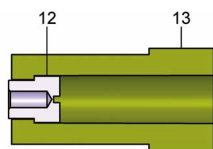

- Install the contact insulator (13) and contact nut (12) into firing head body (7). Tighten the contact nut (12) onto the contact rod (8) with a screwdriver and a deep 5/16 socket or nutdriver.

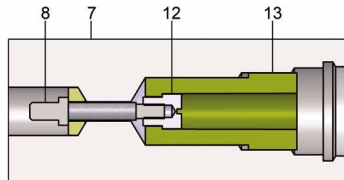

- Install contact spring (6) firmly onto the contact plunger (3) (this will require twisting).



- Place this contact plunger (3) and spring (6) assembly into firing head body (7). With the contact plunger (3) pointing up.

- Install the plunger insulator (5) over the plunger. Depress the spring (6) with the plunger insulator. Install the snap ring (4) to retain the plunger insulator.

- Using pliers, gently twist the contact plunger (3) counter clockwise to ensure spring contact.

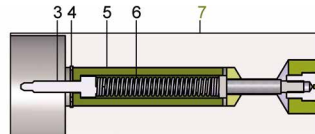

- Install the contact spring (14) into the contact insulator (13). Then place the pin insulator (16) onto the contact pin (15) with the small diameter up.

- Lightly grease the thread on the retainer nut (17). Place the retainer nut onto the pin insulator (16) with the contact pin (15) inside. Then install and tighten with a retaining ring wrench (2010-000-016) while depressing the contact spring (14).

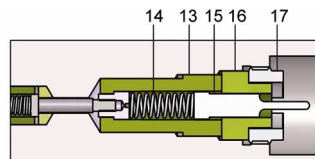

- Install the 0111-220-V95 O-rings (20) and the 0111-112-V95 O-rings (19) onto the igniter holder (22). (Lightly grease the 0111-220-V95 O-rings and threads.)

- Install the igniter (23) into the igniter holder (15) and thread the igniter holder cap (18) over it.

- Install the igniter holder (15). With the igniter (22) installed, into the firing head body (7). Note: left hand thread.

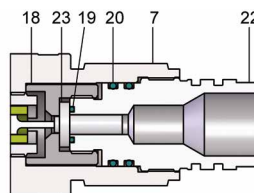

- Install the 0111-222-V95 (21), 0111-227-V95 (11) and 0111-032-V95 (2) O-rings. (Use grease on the 0111-222-V95 and 0111-227-V95 O-rings).

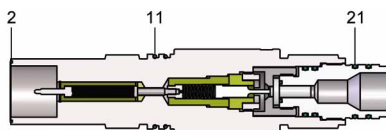

Firing Head Assembly

For Size 10 T-Set® Setting Tool

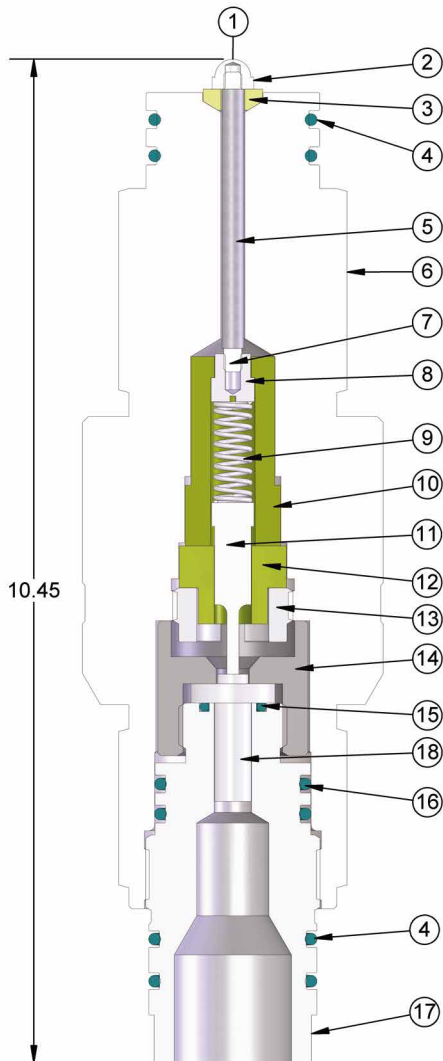

PARTS LIST

| ITEM | PART NUMBER | REQ. | DESCRIPTION |
|------|--------------------|------|--|
| 1 | 2010-000-070 | | Assy. - Firing Head for Size 10 T-Set® Setting Tool - Incl. Items 2-17 |
| 2 | 0330-000-187 | 1 | Acorn Nut |
| 3 | 3903-000-007 | 1 | Insulating Washer |
| 4 | 0111-222-V95 | 4 | O-ring - Viton-95 |
| 5 | 1002-000-4TI-2.700 | 1 | Teflon Insulated Tube |
| 6 | 2010-000-071 | 1 | Firing Head Body |
| 7 | 2010-000-074 | 1 | Contact Rod |
| 8 | 2020-000-006 | 1 | Contact Nut |
| 9 | 2020-000-007 | 1 | Contact Spring |
| 10 | 2020-000-005 | 1 | Contact Insulator |
| 11 | 2020-000-008 | 1 | Contact Pin |
| 12 | 2010-000-005 | 1 | Pin Insulator |
| 13 | 2010-000-004 | 1 | Retainer Nut |
| 14 | 2010-000-015 | 1 | Igniter Holder Cap |
| 15 | 0111-112-V95 | 1 | O-ring - Viton-95 |
| 16 | 0111-220-V95 | 2 | O-ring - Viton-95 |
| 17 | 2010-000-014 | 1 | Igniter Holder |
| 18 | DB-DET-2700-075 | 1 | BP-3 Igniter |

Power Charges and Igniters referenced at the back of this catalog

2010-070-000

Assembly Instructions

1. Place the teflon insulated tube (5) onto the contact rod (7).

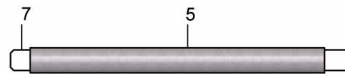

2. Place the contact rod (7) and teflon insulated tube (5) into the insulating washer (3). Install the acorn nut (2) onto the contact rod.

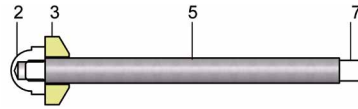

3. Place acorn nut (2), insulating washer (3) and contact rod (7) with insulation (5) into upper end of the firing head body (6).

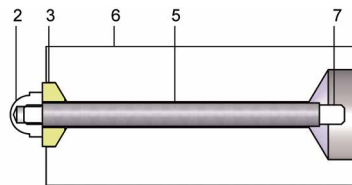

4. Place contact nut (8) into the contact insulator (10).

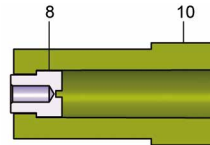

5. Install the contact insulator (10) and contact nut (8) into firing head body (6). Tighten the contact nut (8) onto the contact rod (7) with a screwdriver and a 3/8 socket or nutdriver.

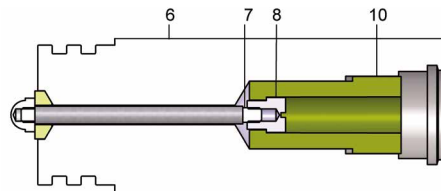

6. Install the contact spring (9) into the contact insulator (10). Then place the pin insulator (12) onto the contact pin (11) with the small diameter up.

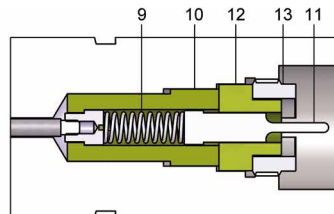

7. Lightly grease the thread on the retainer nut (13). Place the retainer nut onto the pin insulator (12) with the contact pin (11) inside. Then install and tighten with a retaining ring wrench (2010-000-016) while depressing the contact spring (9).

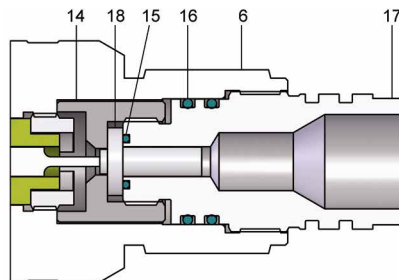

8. Install the 0111-220-V95 O-rings (16) and the 0111-112-V95 O-rings (15) onto the igniter holder (17). (Lightly grease the 0111-220-V95 O-rings and threads.)

9. Install the igniter (18) into the igniter holder (17) and thread the igniter holder cap (14) over it.

10. Install the igniter holder (17). With the igniter (18) installed, into the firing head body (6). Note: left hand thread.

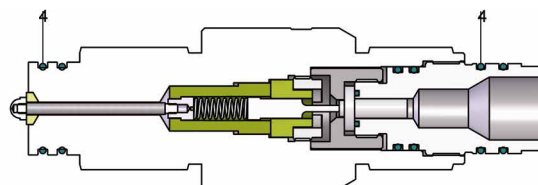

11. Install the 0111-222-V95 (4). (Use grease on the 0111-222-V95 O-rings.)

Firing Head Assembly

For Size 10 T-Set® Setting Tool

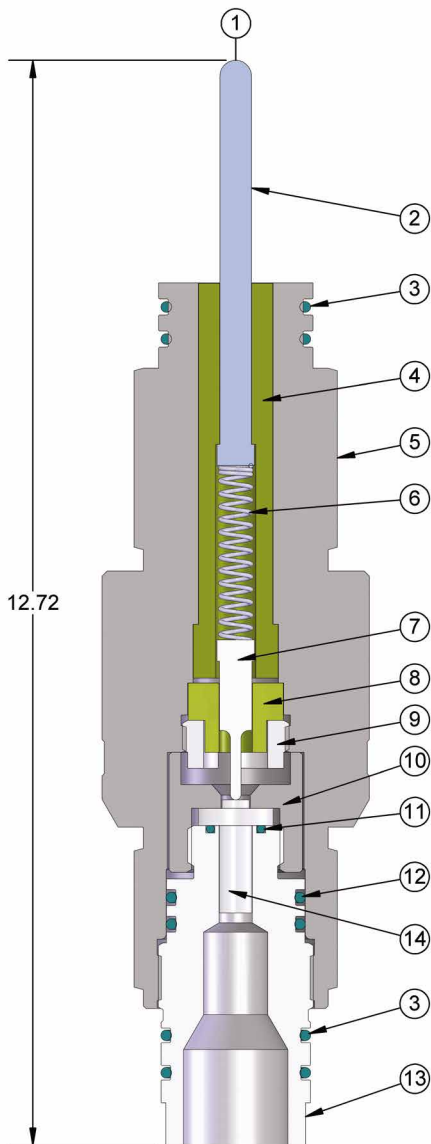

PARTS LIST

| ITEM | PART NUMBER | REQ. | DESCRIPTION |
|------|-----------------|------|--|
| 1 | 2010-000-090 | | Assy. - Firing Head for Size 10 T-Set® Setting Tool - Incl. Items 2-13 |
| 2 | 2010-000-094 | 1 | Contact Stinger |
| 3 | 0111-222-V95 | 4 | O-ring - Viton-95 |
| 4 | 2010-000-093 | 1 | Stinger Insulator |
| 5 | 2010-000-091 | 1 | Firing Head Body |
| 6 | 2010-000-095 | 1 | Contact Spring |
| 7 | 2020-000-008 | 1 | Contact Pin |
| 8 | 2010-000-005 | 1 | Pin Insulator |
| 9 | 2010-000-004 | 1 | Retainer Nut |
| 10 | 2010-000-015 | 1 | Igniter Holder Cap |
| 11 | 0111-112-V95 | 1 | O-ring - Viton-95 |
| 12 | 0111-222-V95 | 2 | O-ring - Viton-95 |
| 13 | 2010-000-014 | 1 | Igniter Holder |
| 14 | DB-DET-2700-075 | 1 | BP-3 Igniter |

Power Charges and Igniters referenced at the back of this catalog

2010-000-090

Assembly Instructions

1. Place the contact stinger (2) into the stinger head body.



2. Place the contact stinger (2) and the stinger head body (4) into the upper end of the firing head body (5).

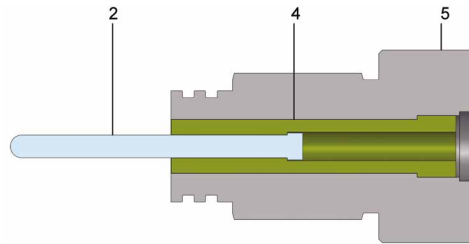

3. Install the contact spring (6) into the stringer insulator (4). Then place the pin insulator (8) onto the contact pin (7) with the small diameter up.

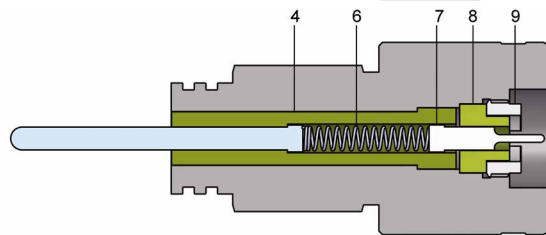

4. Install the 0111-220-V95 O-rings (12) and the 0111-112-V95 O-ring (11) onto the igniter holder (13). (Lightly grease the 0111-220-V95 O-rings and thread.)
5. Install the igniter (14) into the igniter holder (13) and thread the igniter holder cap (10) over it.
6. Install the igniter holder (13), with the igniter installed, into the firing head body (5).

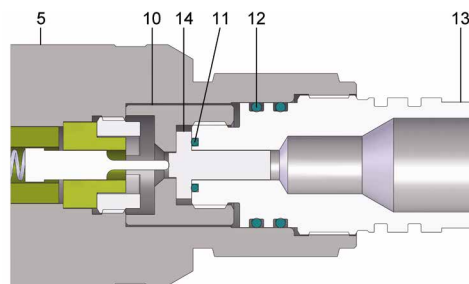

7. Install the 0111-222-V95 O-rings (3). (Use grease on the 0111-222-V95 O-rings.)

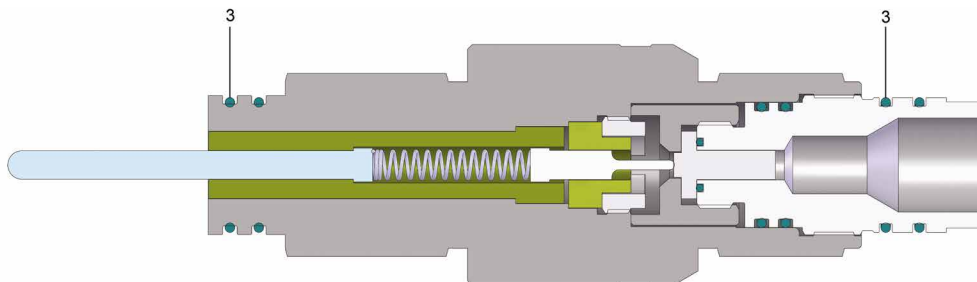

Firing Head Assembly

For Size 20 T-Set® Setting Tool

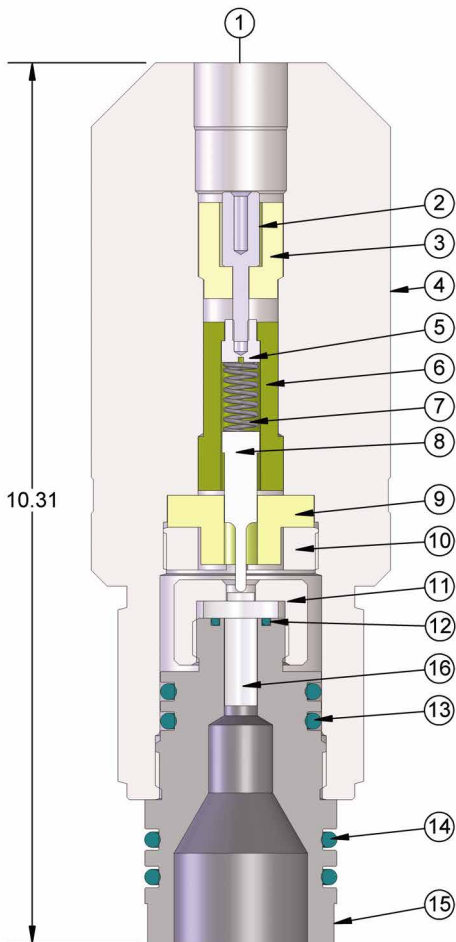

PARTS LIST

| ITEM | PART NUMBER | REQ. | DESCRIPTION |
|------|-----------------|------|--|
| 1 | 2020-000-000 | | Assy. - Firing Head for Size 20 T-Set® Setting Tool - Incl. Items 2-15 |
| 2 | 2020-000-003 | 1 | Contact Socket |
| 3 | 2020-000-004 | 1 | Socket Insulator |
| 4 | 2020-000-001 | 1 | Firing Head Body |
| 5 | 2020-000-006 | 1 | Contact Nut |
| 6 | 2020-000-005 | 1 | Contact Insulator |
| 7 | 2020-000-007 | 1 | Contact Spring |
| 8 | 2020-000-008 | 1 | Contact Pin |
| 9 | 2020-000-009 | 1 | Pin Insulator |
| 10 | 2020-000-010 | 1 | Retainer Ring |
| 11 | 2020-000-015 | 1 | Igniter Holder Cap |
| 12 | 0111-012-V95 | 1 | O-ring - Viton-95 |
| 13 | 0111-325-V95 | 2 | O-ring - Viton-95 |
| 14 | 0111-328-V95 | 2 | O-ring - Viton-95 |
| 15 | 2010-000-014 | 1 | Igniter Holder |
| 16 | DB-DET-2700-075 | 1 | BP-3 Igniter |

Power Charges and Igniters referenced at the back of this catalog

2020-000-000

Assembly Instructions

1. Place this contact socket (2) into the socket insulator (3).

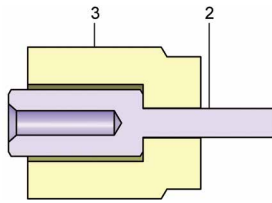

2. Place contact socket (2) and socket insulator (3) into upper end of the firing head body (4).

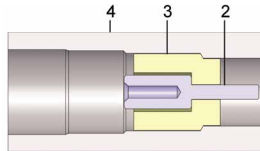

3. Place the contact nut (5) into the contact insulator (6).

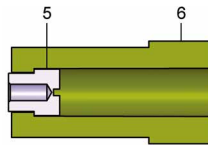

4. Install the contact insulator (6) and contact nut (5) into firing head (4). Tighten the contact nut (5) onto the contact socket (2) with a screwdriver and a deep 3/8 socket or nutdriver.

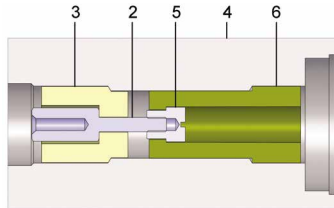

5. Install the contact spring (7) into the contact insulator (6). Then place the pin insulator (9) onto the contact pin (8) with the small diameter up.
6. Lightly grease the thread on the retainer nut (10). Place the retainer nut (10) onto the pin insulator (9) with the contact pin (8) inside. Then install and tighten with a retaining wrench (2010-000-016) while depressing the contact spring (7).

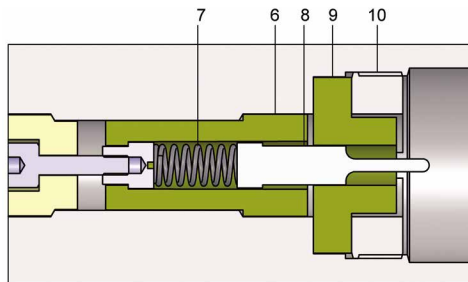

7. Install the 0111-325-V95 O-rings (13) and the 0111-112-V95 O-rings (12) onto the igniter holder (14). (Lightly grease the 0111-325-V95 O-rings and thread.)
8. Install the igniter (16) into the igniter holder (15) and thread the igniter holder cap (11) over it.
8. Install the igniter holder (15) with the igniter (16) installed into the firing head body (4). Note: left hand threads

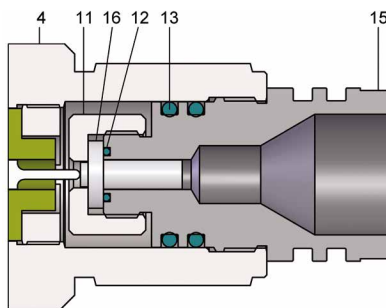

10. Install the 0111-328-V95 O-rings (14). (Use grease on the 0111-328-V95 O-rings.)

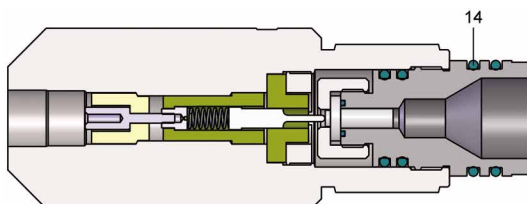

Firing Head Assembly

For Size 20 T-Set® Setting Tool

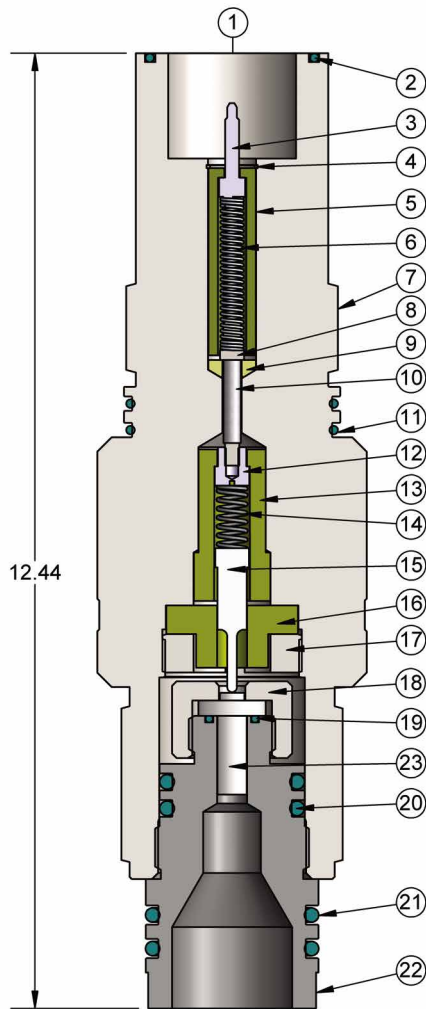

PARTS LIST

| ITEM | PART NUMBER | REQ. | DESCRIPTION |
|------|-----------------|------|--|
| 1 | 2020-000-020 | | Assy. - Firing Head for Size 20 T-Set® Setting Tool - Incl. Items 2-22 |
| 2 | 0111-226-V95 | 1 | O-ring - Viton-95 |
| 3 | 3903-000-010 | 1 | Contact Plunger |
| 4 | 3903-000-012 | 1 | Snap Ring |
| 5 | 3903-000-011 | 1 | Plunger Insulator |
| 6 | 3903-000-009 | 1 | Contact Spring |
| 7 | 2020-000-021 | 1 | Firing Head Body |
| 8 | 2020-000-311 | 1 | Contact Rod |
| 9 | 3903-000-007 | 1 | Insulating Washer |
| 10 | 2020-000-312 | 1 | Teflon Insulated Tube |
| 11 | 0111-230-V95 | 2 | O-ring - Viton-95 |
| 12 | 2020-000-006 | 1 | Contact Nut |
| 13 | 2020-000-005 | 1 | Contact Insulator |
| 14 | 2020-000-007 | 1 | Contact Spring |
| 15 | 2020-000-008 | 1 | Contact Pin |
| 16 | 2020-000-009 | 1 | Pin Insulator |
| 17 | 2020-000-010 | 1 | Retainer Ring |
| 18 | 2020-000-015 | 1 | Igniter Holder Cap |
| 19 | 0111-112-V95 | 1 | O-ring - Viton-95 |
| 20 | 0111-325-V95 | 2 | O-ring - Viton-95 |
| 21 | 0111-328-V95 | 2 | O-ring - Viton-95 |
| 22 | 2020-000-014 | 1 | Igniter Holder |
| 23 | DB-DET-2700-075 | 1 | BP-3 Igniter |

Power Charges and Igniters referenced at the back of this catalog

2020-000-020

Assembly Instructions

- Place the teflon insulated tube (10) onto the contact rod (8).

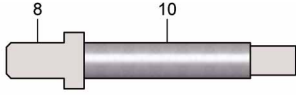

- Place the contact rod (8) and teflon insulated tube (10) into the insulating washer (9). Use care to ensure that the taper side faces away from the hex shaped portion of the contact rod.

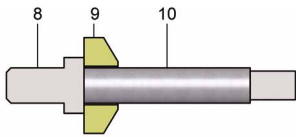

- Place insulating washer (9) and contact rod (8) with insulation (10) into upper end of the firing head body (7).

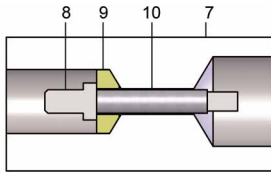

- Place contact nut (12) into the contact insulator (13).

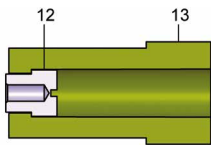

- Install the contact insulator (13) and contact nut (12) into firing head body (7). Tighten the contact nut (12) onto the contact rod (8) with a screwdriver and a deep 3/8 socket or nutdriver.

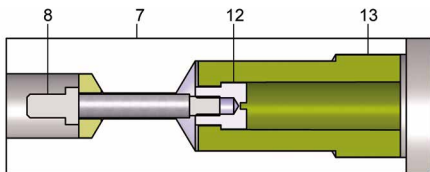

- Install contact spring (6) firmly onto the contact plunger (3) this will require twisting).



- Place this contact plunger and spring assembly into firing head body (7). With the contact plunger (3) pointing up.

- Install the plunger insulator (5) over the plunger. Depress the spring (6) with the plunger insulator. Install the snap ring (4) to retain the plunger insulator.

- Using pliers, gently twist the contact plunger (3) counter clockwise to ensure spring contact.

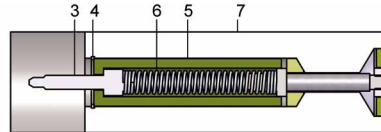

- Install the contact spring (14) into the contact insulator (13). Then place the pin insulator (16) onto the contact pin (15) with the small diameter up.

- Lightly grease the thread on the retainer nut (17). Place the retainer nut onto the pin insulator (16) with the contact pin (15) inside. Then install and tighten with a retaining ring wrench (2010-000-016) while depressing the contact spring (14).

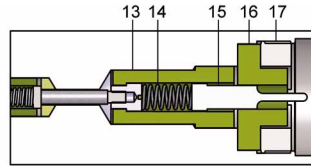

- Install the 0111-325-V95 O-rings (20) and the 0111-112-V95 O-rings (19) onto the igniter holder (22). (Lightly grease the 0111-325-V95 O-rings and threads.)

- Install the igniter (23) into the igniter holder (22) and thread the igniter holder cap (18) over it.

- Install the igniter holder (22). With the igniter (23) installed, into the firing head body (7). Note: left hand threads.

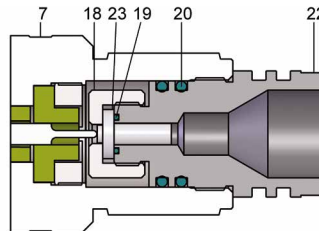

- Install the 0111-328-V95 (21), 0111-230-V95 (11) and 0111-226-V95 (2) O-rings. (Use grease on the 0111-328-V95 and 0111-230-V95 O-rings).

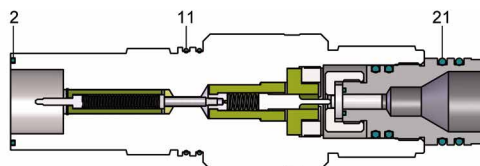

Firing Head Assembly

For Size 20 T-Set® Setting Tool

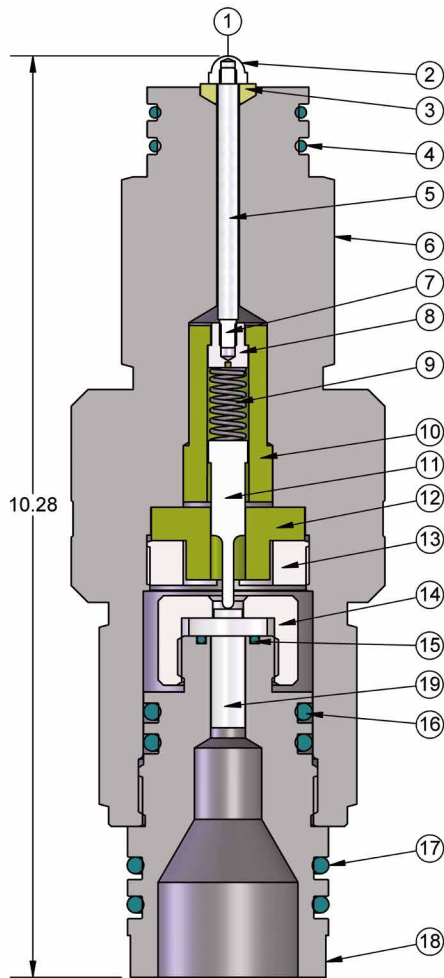

PARTS LIST

| ITEM | PART NUMBER | REQ. | DESCRIPTION |
|------|--------------------|------|--|
| 1 | 2020-000-070 | | Assy. - Firing Head for Size 20 T-Set® Setting Tool - Incl. Items 2-18 |
| 2 | 0330-000-184 | 1 | Acorn Nut |
| 3 | 3903-000-007 | 1 | Insulating Washer |
| 4 | 0111-222-V95 | 2 | O-ring - Viton-95 |
| 5 | 1002-000-4TI-2.630 | 1 | Teflon Insulated Tube |
| 6 | 2020-000-071 | 1 | Firing Head Body |
| 7 | 2010-000-074 | 1 | Contact Rod |
| 8 | 2020-000-006 | 1 | Contact Nut |
| 9 | 2020-000-007 | 1 | Contact Spring |
| 10 | 2020-000-005 | 1 | Contact Insulator |
| 11 | 2020-000-008 | 1 | Contact Pin |
| 12 | 2020-000-009 | 1 | Pin Insulator |
| 13 | 2020-000-010 | 1 | Retainer Ring |
| 14 | 2020-000-015 | 1 | Igniter Holder Cap |
| 15 | 0111-112-V95 | 1 | O-ring - Viton-95 |
| 16 | 0111-325-V95 | 2 | O-ring - Viton-95 |
| 17 | 0111-328-V95 | 2 | O-ring - Viton-95 |
| 18 | 2020-000-014 | 1 | Igniter Holder |
| 19 | DB-DET-2700-075 | 1 | BP-3 Igniter |

Power Charges and Igniters referenced at the back of this catalog

2020-000-070

Assembly Instructions

1. Place the teflon insulated tube (5) onto the contact rod (7).



2. Place the contact rod (7) and teflon insulated tube (5) into the insulating washer (3). Install the acorn nut (2) onto the contact rod.

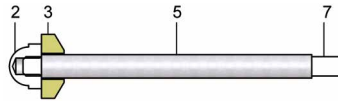

3. Place acorn nut (2), insulating washer (3) and contact rod (7) with insulation (5) into upper end of the firing head body (6).

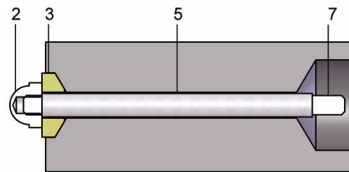

4. Place contact nut (8) into the contact insulator (10).

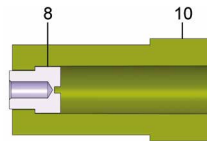

5. Install the contact insulator (10) and contact nut (8) into firing head body (6). Tighten the contact nut (8) onto the contact rod (7) with a screwdriver and a 3/8 socket or nutdriver.

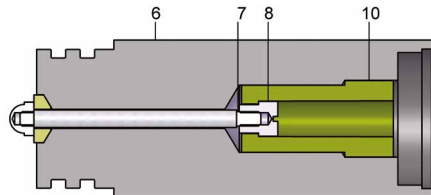

6. Install the contact spring (9) into the contact insulator (10). Then place the pin insulator (12) onto the contact pin (11) with the small diameter up.

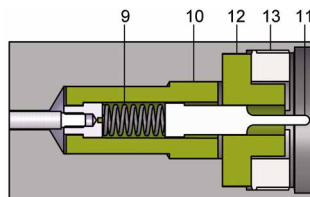

7. Lightly grease the thread on the retainer nut (13). Place the retainer nut onto the pin insulator (12) with the contact pin (11) inside. Then install and tighten with a retaining ring wrench (2010-000-016) while depressing the contact spring (9).

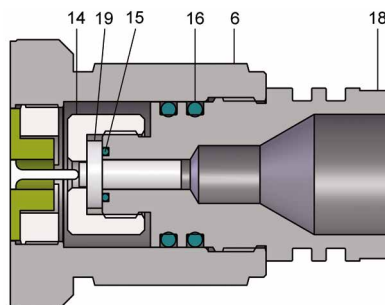

8. Install the 0111-325-V95 O-rings (16) and the 0111-112-V95 O-rings (15) onto the igniter holder (18). (Lightly grease the 0111-325-V95 O-rings and threads.)

9. Install the igniter (19) into the igniter holder (18) and thread the igniter holder cap (14) over it.

10. Install the igniter holder (18). With the igniter (19) installed, into the firing head body (6). Note: left hand thread.

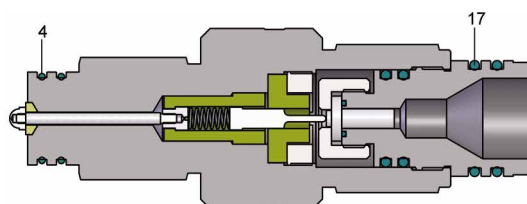

11. Install the 0111-328-V95 (4) and 0111-328-V95 (17). (Use grease on the 0111-222-V95 and 0111-328-V95 O-rings.)

Firing Head Assembly

For 1-1/2 in., 1-11/16 in., 2-1/8 in. & 2-1/2 in. T-Set® Setting Tool

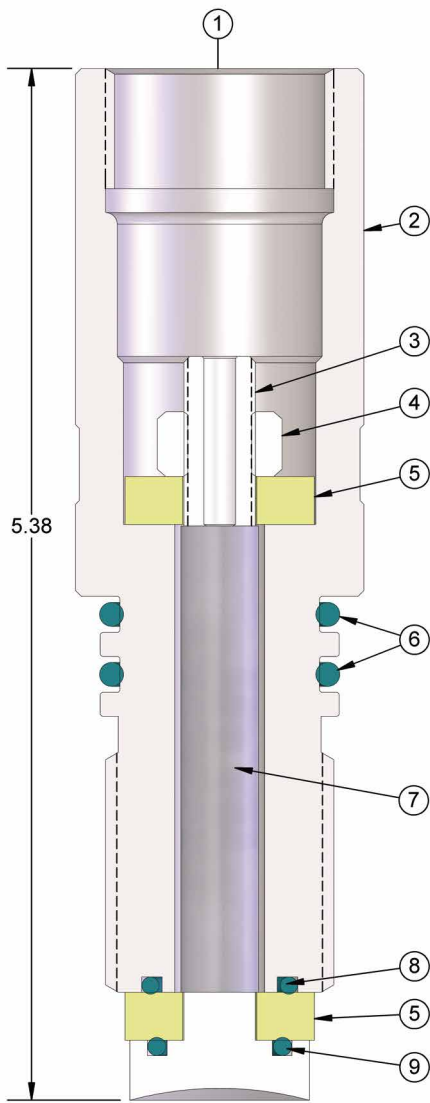

PARTS LIST

| ITEM | PART NUMBER | REQ. | DESCRIPTION |
|------|--------------------|------|--|
| 1 | 6110-000-000 | | Assy. - Firing Head for T-Set® Setting Tool - Incl. Items 2-15 |
| 2 | 6110-000-001 | 1 | Firing Head Body |
| 3 | 6110-000-003 | 1 | Contact Rod |
| 4 | 1012-000-004 | 1 | Hex Nut - 3/8-24 Unf |
| 5 | 1012-000-005 | 2 | Insulating Washer |
| 6 | 0111-214-V95 | 2 | O-ring - Viton-95 |
| 7 | 0256-000-4TI-2.430 | 1 | Teflon Insulated Tube |
| 8 | 0111-114-V95 | 1 | O-ring - Viton-95 |
| 9 | 0111-113-V95 | 1 | O-ring - Viton-95 |

Power Charges and Igniters referenced at the back of this catalog

6110-000-000

Assembly Instructions

1. Install the 0111-113-V95 (9) O-ring onto the contact rod (3). Place insulating washer (5) onto the contact rod. Then install the teflon insulated tube (7) onto the contact rod.

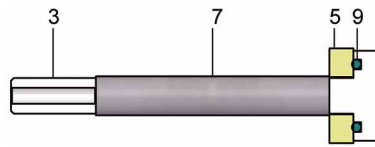

2. Install the 0111-114-V95 (8) O-ring onto the firing head body (2). Then place the insulating washer (5) and contact rod (3) with insulation into the lower end of the firing head body.

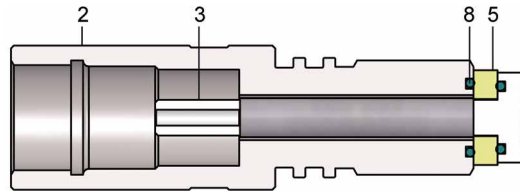

3. Place the insulating washer (5) into the upper end of the firing head body (2). Placing the insulating washer onto the contact rod (3).

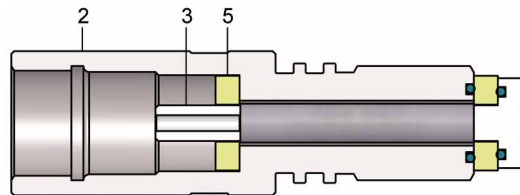

4. Tighten the hex nut (4) onto the contact rod (3).

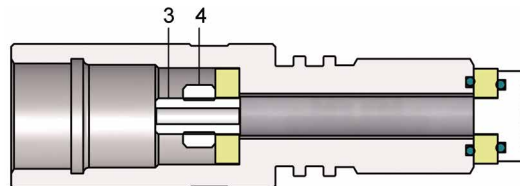

5. Install the 0111-214-V95 (6) O-rings onto the firing head body (2).

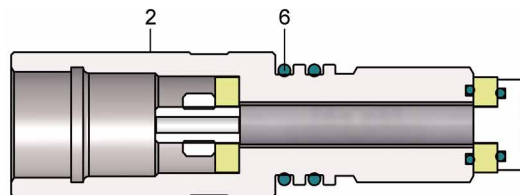

T-Set® Adapter Kit

1-1/2 in. Shorty to 1-11/16 in. Setting Adapters

PARTS LIST

| ITEM | PART NUMBER | REQ. | DESCRIPTION |
|------|--------------|------|---|
| 1 | WST-1500-040 | | Assy. - Adapt. Kit - 1-11/16 in. O.D. Setting Tool - Setting Adapters - Incl. Items 2-4 |
| 2 | WST-1500-041 | 1 | Adapter Sleeve |
| 3 | WST-1500-042 | 1 | Adapter Rod |
| 4 | WST-1718-030 | 1 | Lock Ring |

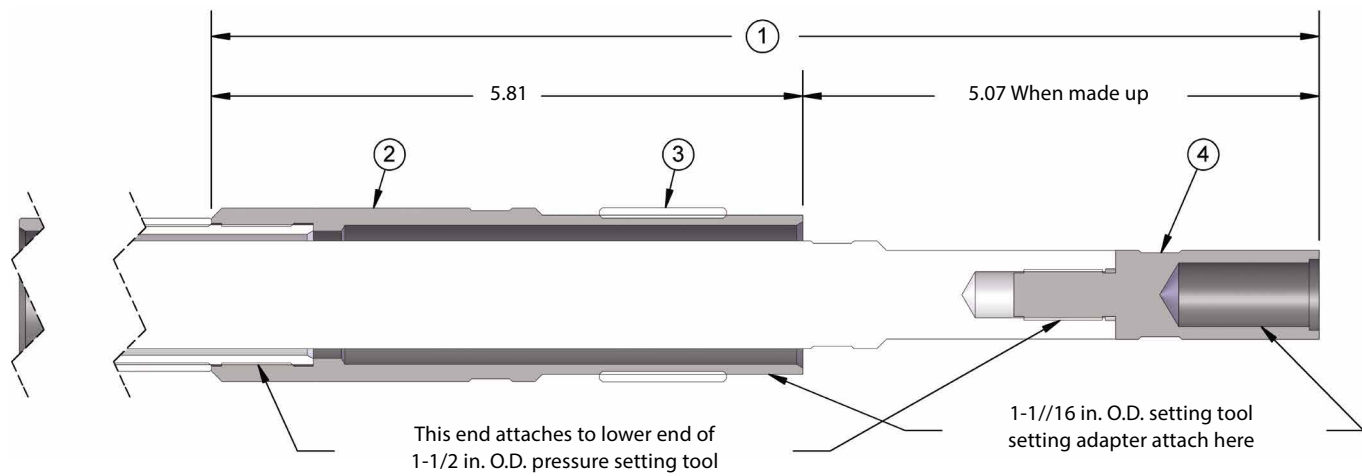

T-Set® Adapter Kit

2-1/2 in. Shorty to T-Set® Size 10 Setting Equipment

PARTS LIST

| ITEM | PART NUMBER | REQ. | DESCRIPTION |
|------|--------------|------|--|
| 1 | WST-2500-040 | | Assy. - Adapt. Kit - T-Set® Size #10 Setting Equipment - Incl. Items 2-3 |
| 2 | WST-2500-041 | 1 | Adapter Sleeve |
| 3 | WST-2500-042 | 1 | Adapter Rod |

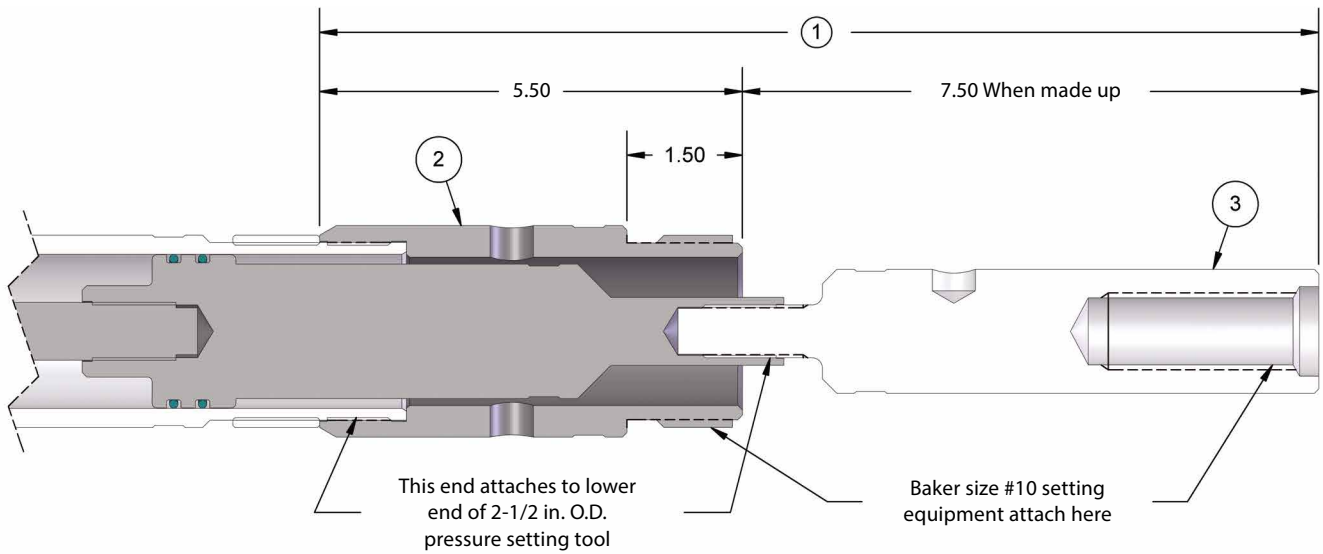

T-Set® Adapter Kit

3-1/2 in. & 3-5/8 in. to T-Set® Size 10 Setting Equipment

PARTS LIST

| ITEM | PART NUMBER | REQ. | DESCRIPTION |
|------|--------------|------|--|
| 1 | WST-5303-117 | | Assy. - Adapt. Kit - T-Set® Size #10 Setting Equipment - Incl. Items 2-4 |
| 2 | WST-5303-118 | 1 | Adapter Sleeve |
| 3 | WST-3625-131 | 1 | Lock Nut |
| 4 | WST-5303-119 | 1 | Adapter Rod |

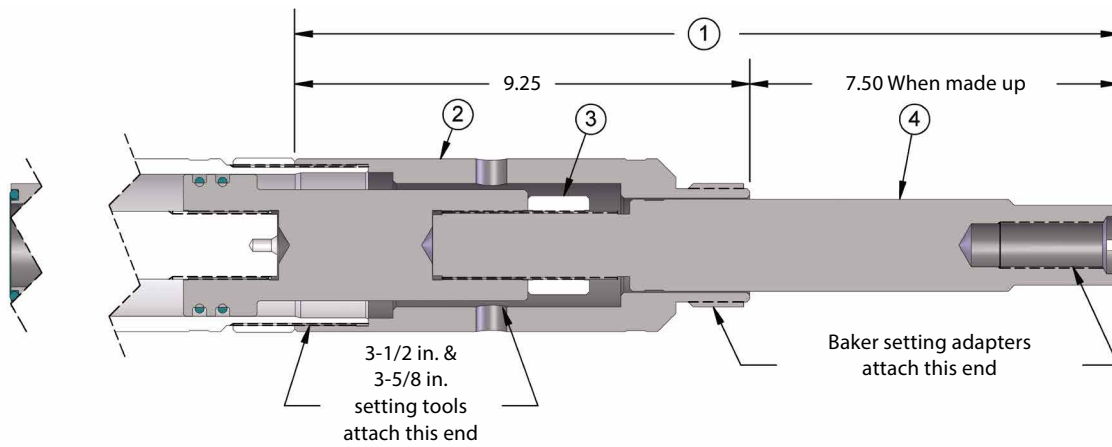

T-Set® Adapter Kit

3-1/2 in. & 3-5/8 in. to T-Set® Size 20 Setting Equipment

PARTS LIST

| ITEM | PART NUMBER | REQ. | DESCRIPTION |
|------|--------------|------|--|
| 1 | WST-5303-120 | | Assy. - Adapt. Kit - T-Set® Size #20 Setting Equipment - Incl. Items 2-4 |
| 2 | WST-5303-121 | 1 | Adapter Sleeve |
| 3 | WST-3625-131 | 1 | Lock Nut |
| 4 | WST-5303-122 | 1 | Adapter Mandrel |

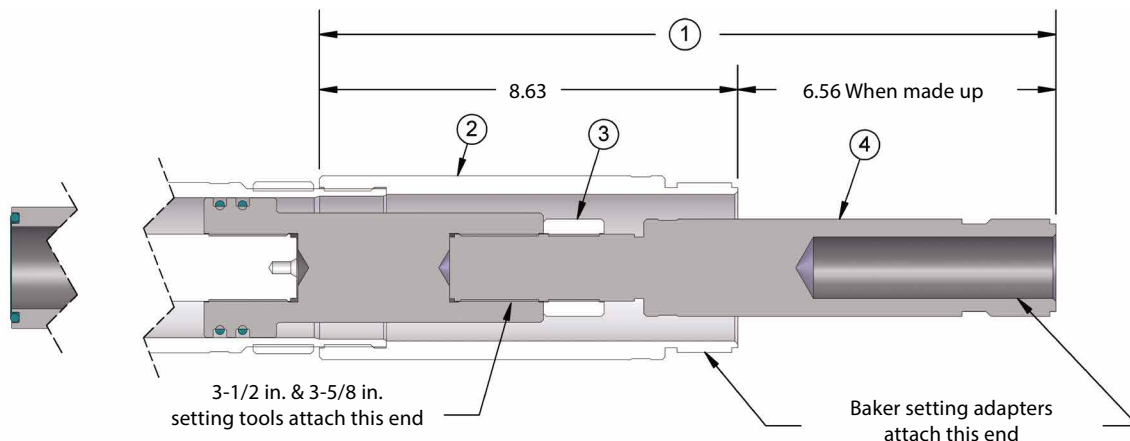

Inspection Kits

The Hunting “T-Set” Inspection System is designed to help maintain the working integrity of your “T-Set” Setting tools. This kit was developed to provide all of the necessary measuring equipment to accurately inspect the critical components of your setting tools. The WST- KIT-INSP-10-20 will cover a wide variety of tools ranging from the 2.125” MSST to the T-Set #20. The WST-KIT-INSP-UNIV covers our complete tool line beginning with 1.50” OD Shorty all the way through our T-Set #20. The kits include necessary mics, calipers, bore gauges, radius gauge, taps, aluminum oil level gauge, a fully detailed instruction manual and carrying case. On-site training to properly use the system is also available, upon request.

WST-KIT-INSP-10-20 - Inspection Kit

For WST-2125, WST-2500, WST-3250, WST-5321, WST-3625, WST-BK10 & WST-BK20 Series Setting Tools

This kit comes complete in an easy to carry Pelican™ case and includes:

- Instruction manual
- 1.00 in. - 2.00 in. Vernier micrometer
- 2.00 in. - 3.00 in. Vernier micrometer
- 1.4 in. - 6.00 in. Dial bore gage
- .75 in. - 1.75 in. Internal dial caliper gauge
- Radius gage
- 6.00 in. Dial caliper
- 1-1/4 - 12 Left hand tap
- Oil level gauge



WST-KIT-INSP-10-20



1.00 in. - 2.00 in. Vernier micrometer
2.00 in. - 3.00 in. Vernier micrometer



6.00 in. Dial caliper



1.4 in. - 6.00 in. Dial bore gage



1-1/4 - 12 Left hand tap



.75 in. - 1.75 in. Internal dial caliper gauge



Oil level gauge



Radius gage

WST-KIT-INSP-UNIV - Inspection Kit

For WST-1500, WST-1718, WST-2125, WST-2500, WST-3250, WST-5321, WST-3625, WST-BK05, WST-BK10 & WST-BK20 Series Setting Tools

This kit comes complete in an easy to carry Pelican™ case and includes:

- Instruction manual
- 0 - 1.00 in. Vernier micrometer
- 1.00 in. - 2.00 in. Vernier micrometer
- 2.00 in. - 3.00 in. Vernier micrometer
- .700 in. - 1.500 in. Dial bore gage
- 1.4 in. - 6.00 in. Dial bore gage
- .75 in. - 1.75 in. Internal dial caliper gage
- Radius gage
- 6.00 in. Dial caliper
- 3/4 - 16 Left hand tap
- 1-1/4 - 12 Left hand tap
- Oil level gage



WST-KIT-INSP-UNIV



0 - 1.00 in. Vernier micrometer
1.00 in. - 2.00 in. Vernier micrometer
2.00 in. - 3.00 in. Vernier micrometer



6.00 in. Dial caliper



.700 in. - 1.500 in. Dial bore gage
1.4 in. - 6.00 in. Dial bore gage



3/4 - 16 Left hand tap
1-1/4 - 12 Left hand tap



.75 in. - 1.75 in. Internal dial caliper gage



Oil level gage



Radius gage

Power Chargers and Igniters

For T-Set® Tools

| Setting Tool Description | Part Numbers for Power Chargers and Igniters | |
|---------------------------------------|--|------------------|
| "GO" Style T-Set® | Power Charges | Primary Igniter |
| 1.50 in. (3.81 cm) O.D. Single Stage | DB-HDO-1500-100 | DB-DET-2700-0741 |
| 1.71 in. (4.34 cm) O.D. Single Stage | DB-HDO-1500-100 | |
| 2.50 in. (6.35 cm) O.D. Single Stage | DB-HDO-2500-200 | |
| 3.50 in. (8.89 cm) O.D. Single Stage | DB-HDO-3500-100 | |
| 3.63 in. (9.21 cm) O.D. Single Stage | DB-HDO-3625-100 | |
| 3.63 in. (9.21 cm) O.D. High Pressure | DB-HDO-3625-100 | |
| 1.71 in. (4.34 cm) O.D. Multi-Stage | DB-HDO-1687-100 | |
| 2.13 in. (5.40 cm) O.D. Multi-Stage | DB-HDO-3625-100 | |
| 3.25 in. (8.25 cm) O.D. Multi-Stage | JEC-5336-099 | |
| 4.50 in. (11.43 cm) O.D. Multi-Stage | Call for Availability | |

Diamond Back Charges and Igniters

| T-Set® Setting Tool | Slow Set Charges | Standard Charges | Primary Igniters | Secondary Igniter |
|---------------------|------------------|------------------|--|-------------------|
| Size 05 | N/A | DB-BPC-0800-005S | DB-DET-2700-075 BP3 DB-DET-2700-075 (4) BP4 | DET-2700-076 |
| Size 10 | DB-BPC-1300-010 | DB-BPC-1300-010S | | |
| Size 20 | DB-BPC-1500-020 | DB-BPC-1500-020S | | |

Baker Hughes Charges and Igniters

| T-Set® Setting Tool | Slow Set Charges | Standard Charges | Primary Igniters | Secondary Igniters |
|---------------------|------------------|------------------|---|--------------------|
| Size 05 | N/A | BOT-H437641500 | BP-3S: BOT-H437442200 BP-4S: BOT-H437444200 BP-5S: BOT-H437440001 | BOT-H437431000 |
| Size 10 | BOT-H437660010 | BOT-H437642113 | | |
| Size 20 | BOT-H437660020 | BOT-H437643223 | | |